



APE Pile Driving Course:
Understanding Pile Driving Leads

Pile Driving Leads

- Box lead dimensions
- Box lead swinging
- Box lead – clip on type
- Box lead, fixed, extended
- Box lead, semi-fixed travel
- Flying hammer with boot
- Fork Lift
- Excavator mounted
- European FEC leads
- Berminghammer type leads

Swinging leads

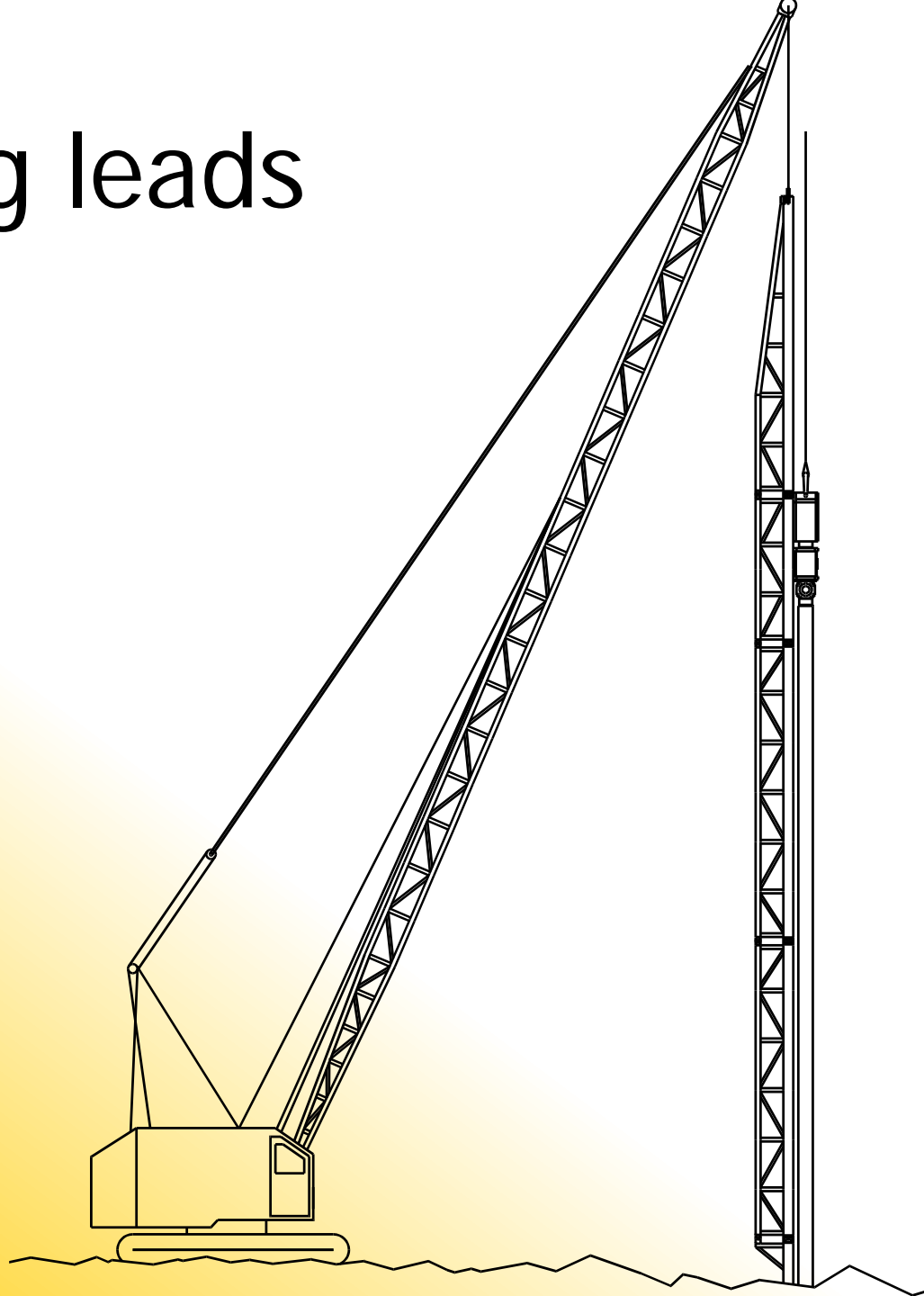

Swinging Box
Lead 8 by 32"



Understanding Box Leads Dimensions

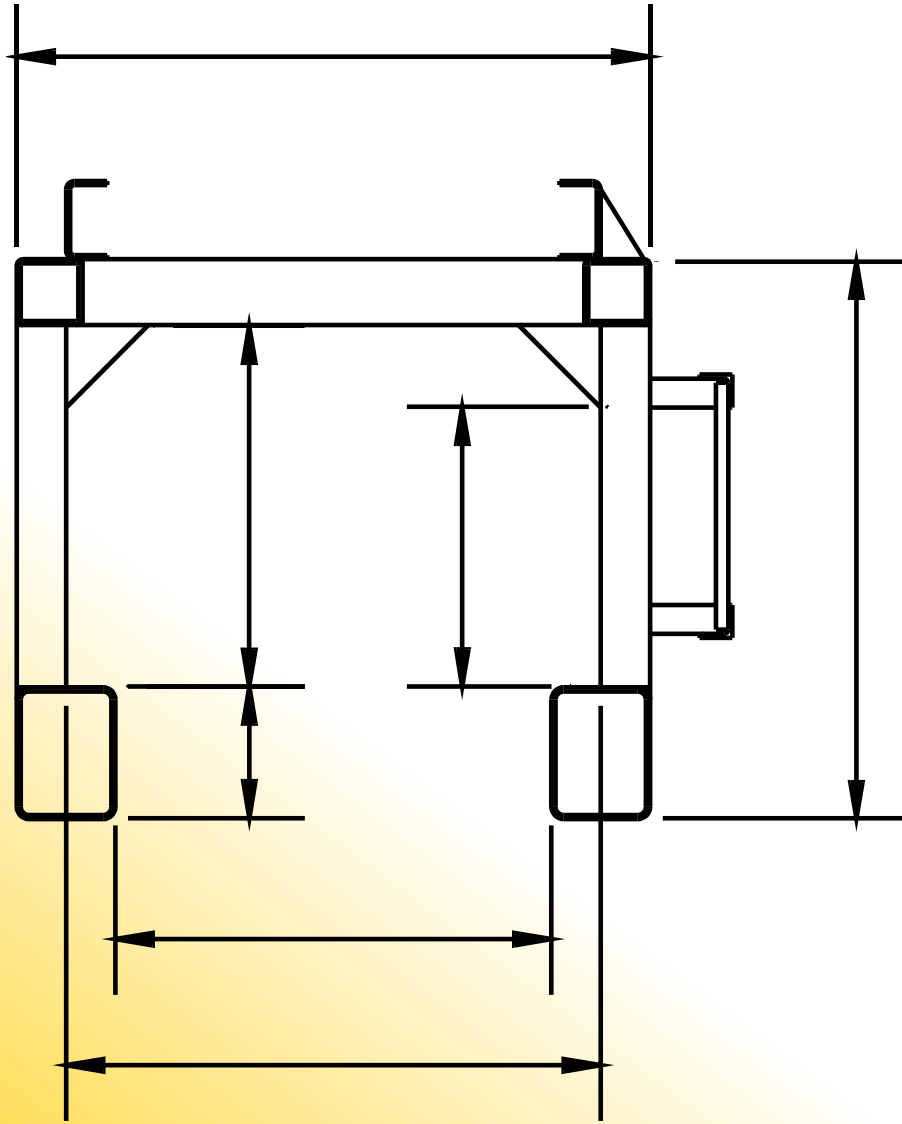

Typical Box Lead with Hammer

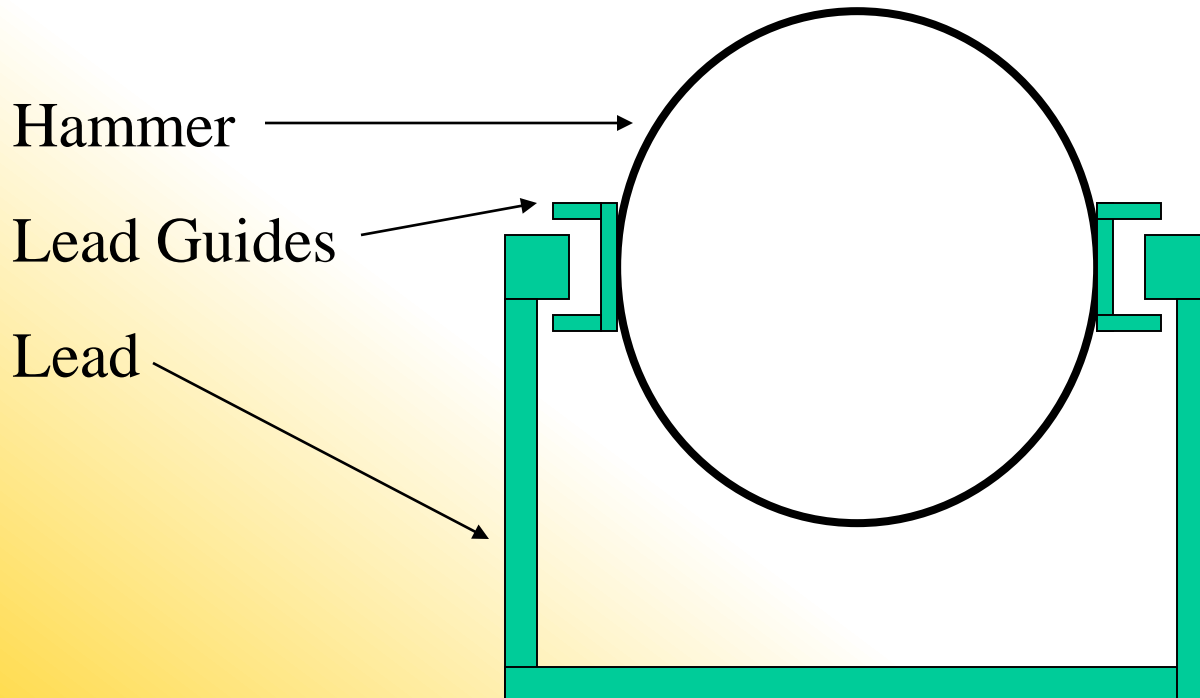

Diesel Hammer

Leads, Box

8 by 32"

Trip guide tubes



Standard Box Lead Sizes

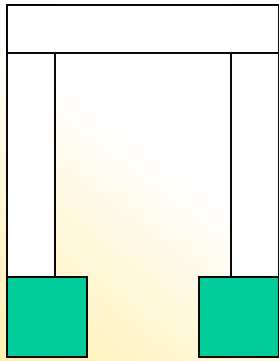

8 by 20"

Small hammers such as D8, D16 or D19 max.

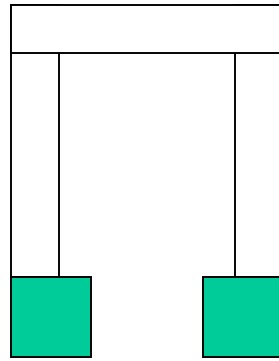

8 by 26"

Most common size leads in the industry. Hammers up to about 70,000 ft-lbs or D-30.

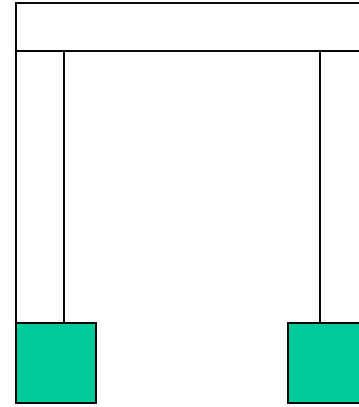

8 by 32"

Becoming most popular lead size. D36, D46, D62 size hammers.

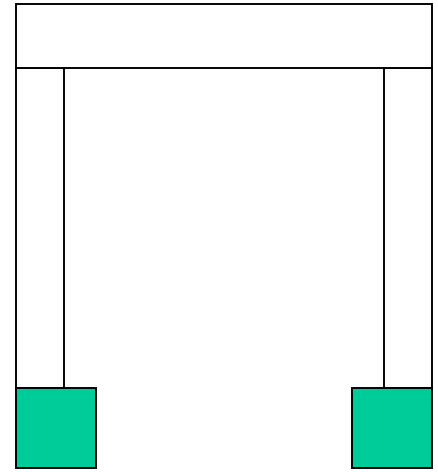

8 by 37"

Used when contractor needs to drive larger pile sizes.

Non-Standard Box Lead Sizes

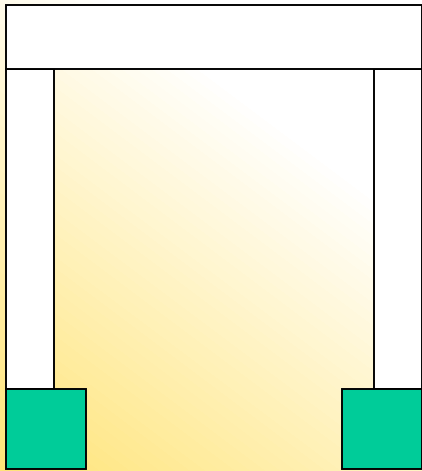

43''

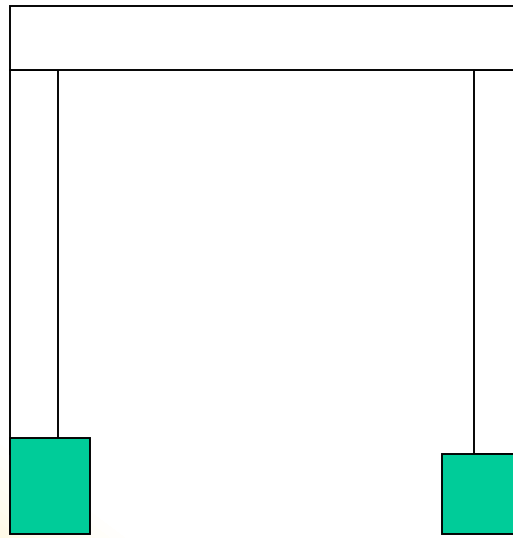

56''

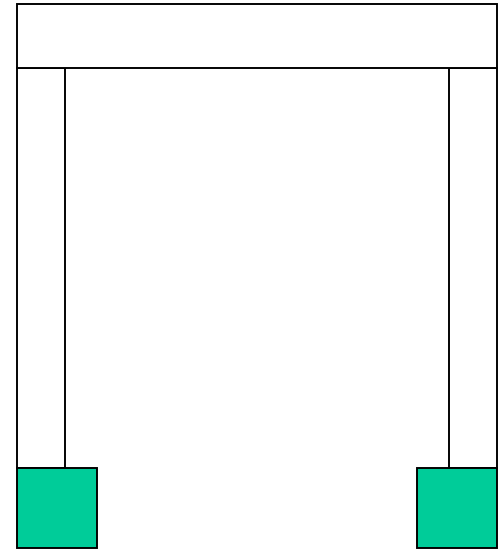

72 or 78''

Typical Lead Lengths

20 foot taper top

10 footer

40 footer

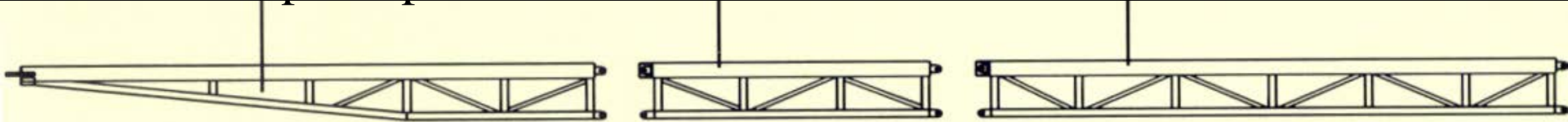

Bottom Stabber Section

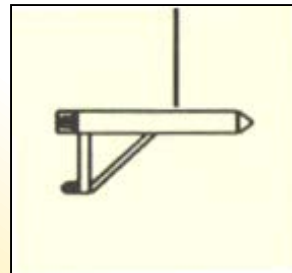

Connecting Box Leads

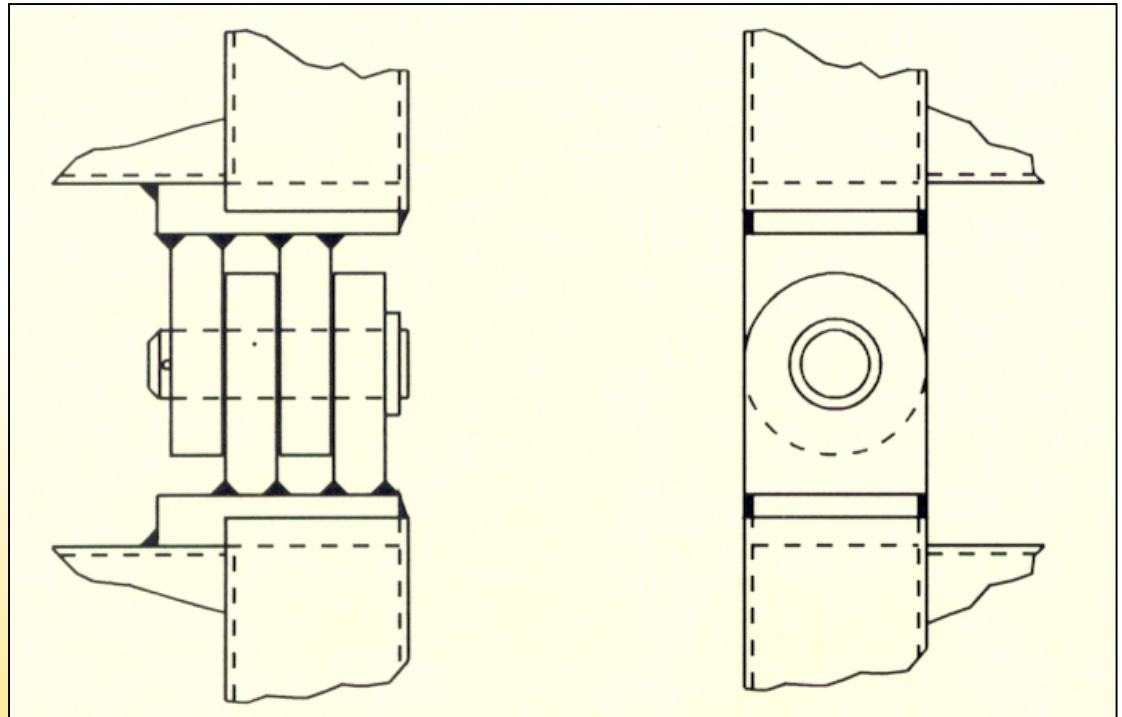
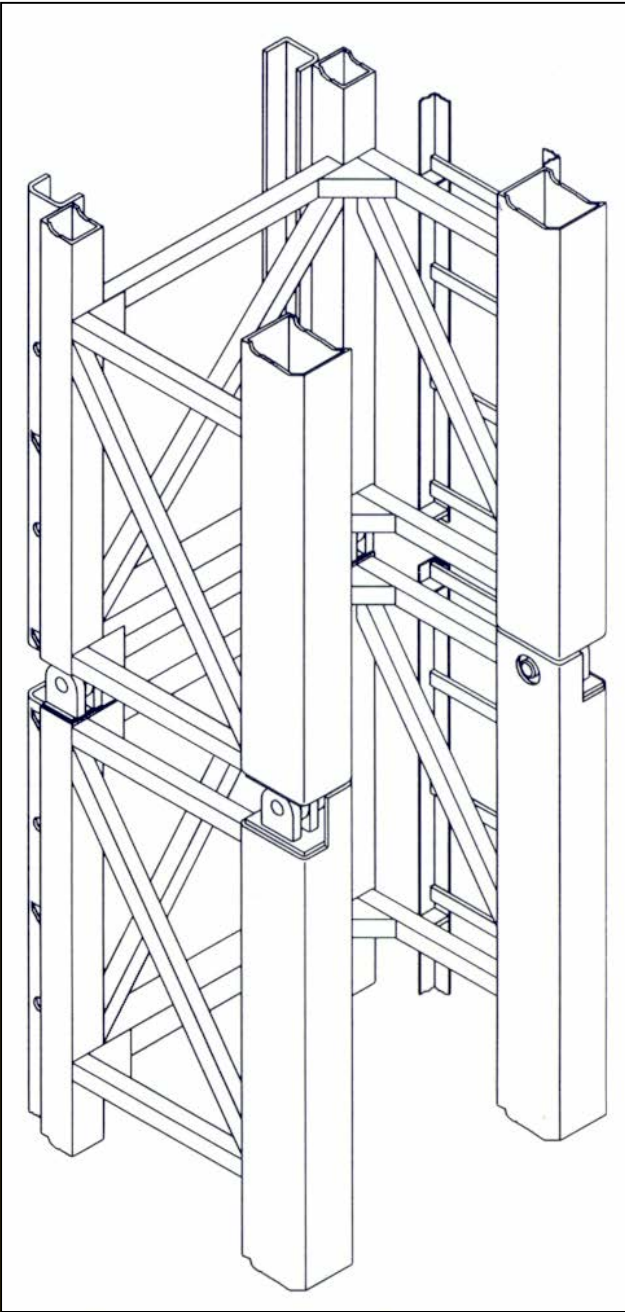

Example of Bolt Type Connection

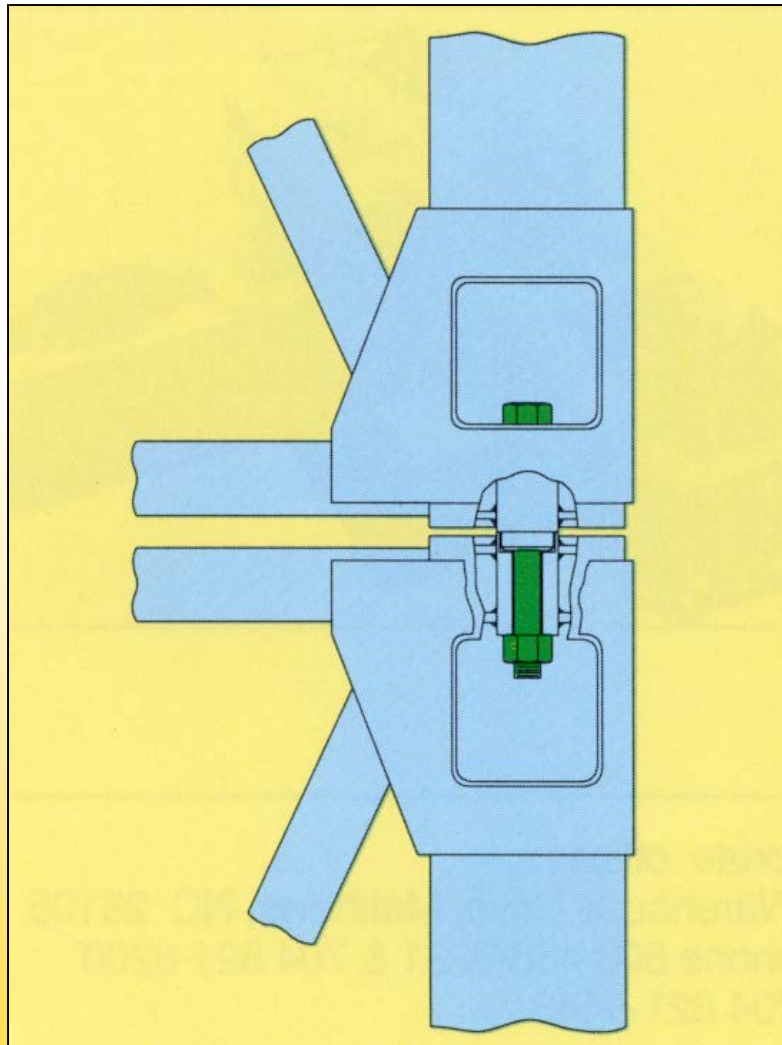

This is a standard LB Foster or ICE bolt together type lead connection.

Diesel
Hammer
with lead
guides for
8 by 26
inch leads



Swinging Box
Leads
8 by 32"



Hammer line

Lead line

Rigging to top of swinging leads



Note: Shackles pins must be wired off!

Two part sheave block with swivel. Long cable is treaded through the trip sheave and back to the hook. This keeps the block away from the diesel hammer piston.

Sheave on trip

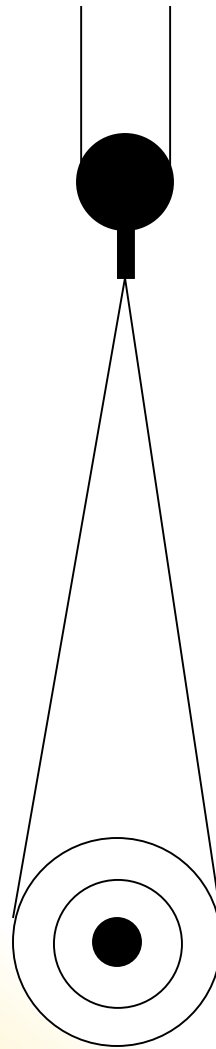

Note how a long cable is used to rig tripping device.





Fixed, Extended
leads and
Swinging Box
Leads with Taper
Top
8 by 32"





Swinging Leads
With Roller At Top

Fixed, Extended Leads

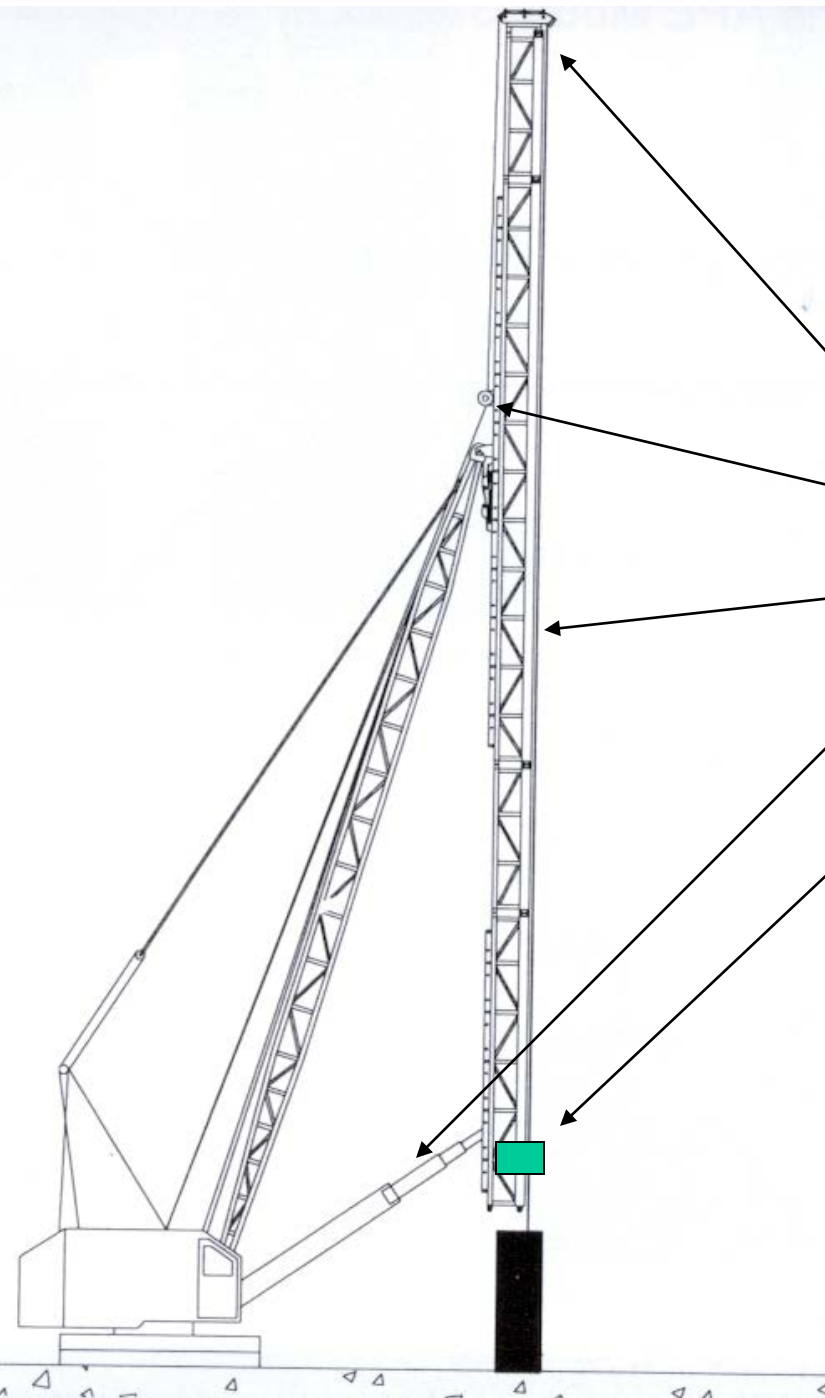

Headblock

Rooster Sheaves

Leads

Spotter

Gate

Requires more components than simple swinging lead set up.

LAYOUT CONSIDERATIONS

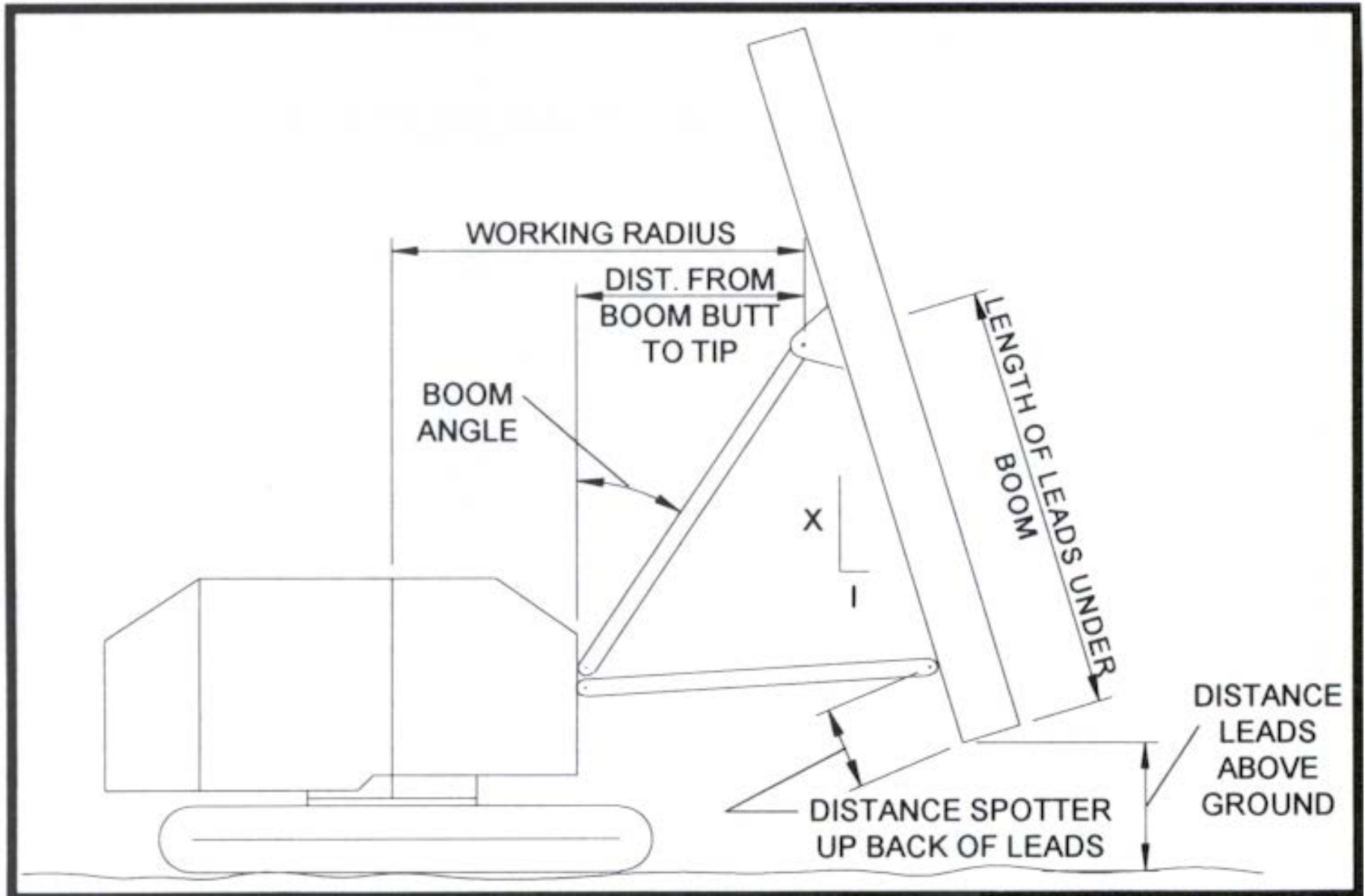

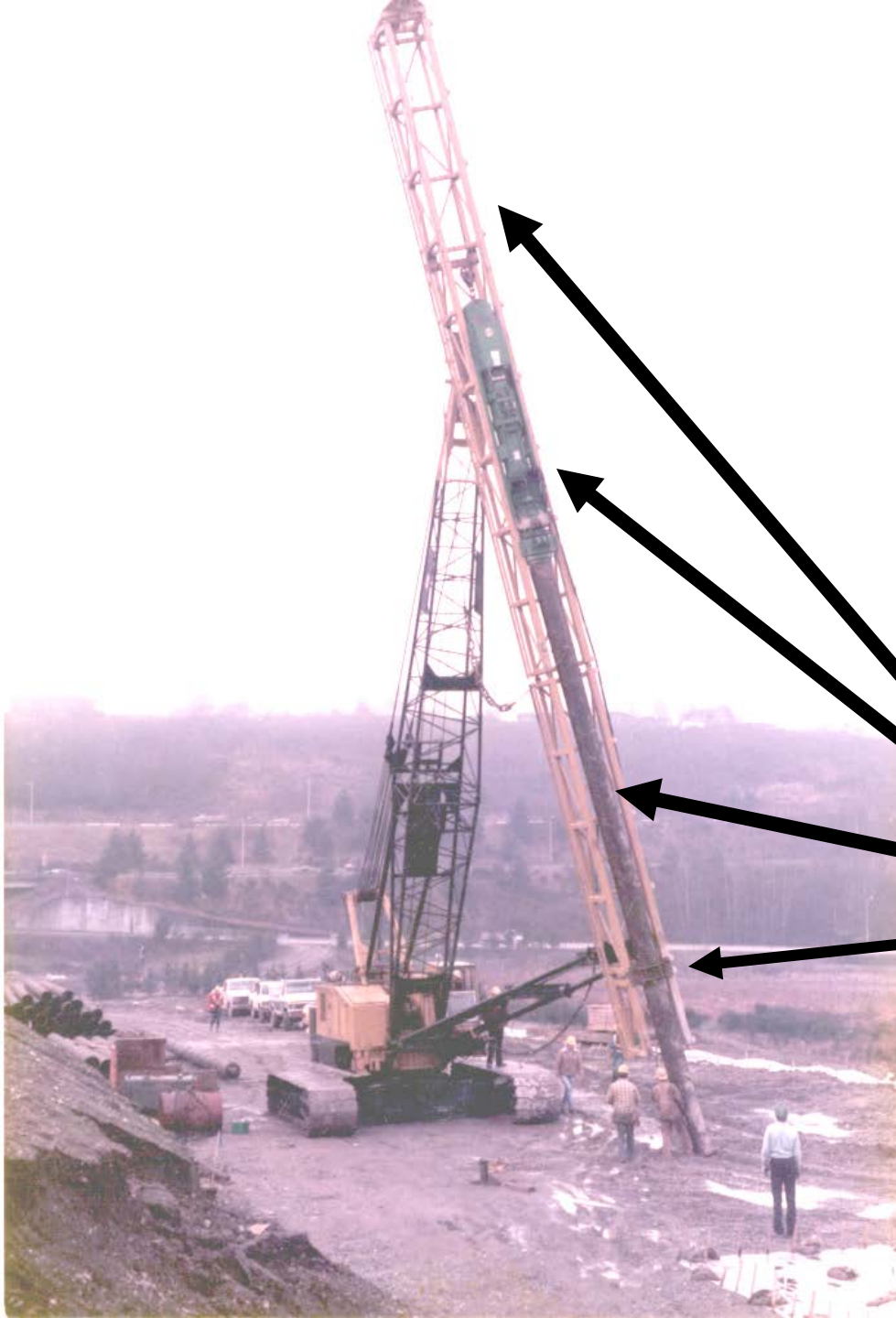

Fixed, Extended Lead

Lead, extended above crane boom

Diesel hammer

24 inch pipe piles

Pile Gate (Combination Rabbit)

**Note: Spotter pushing lead into a
batter position called**

“left side batter”

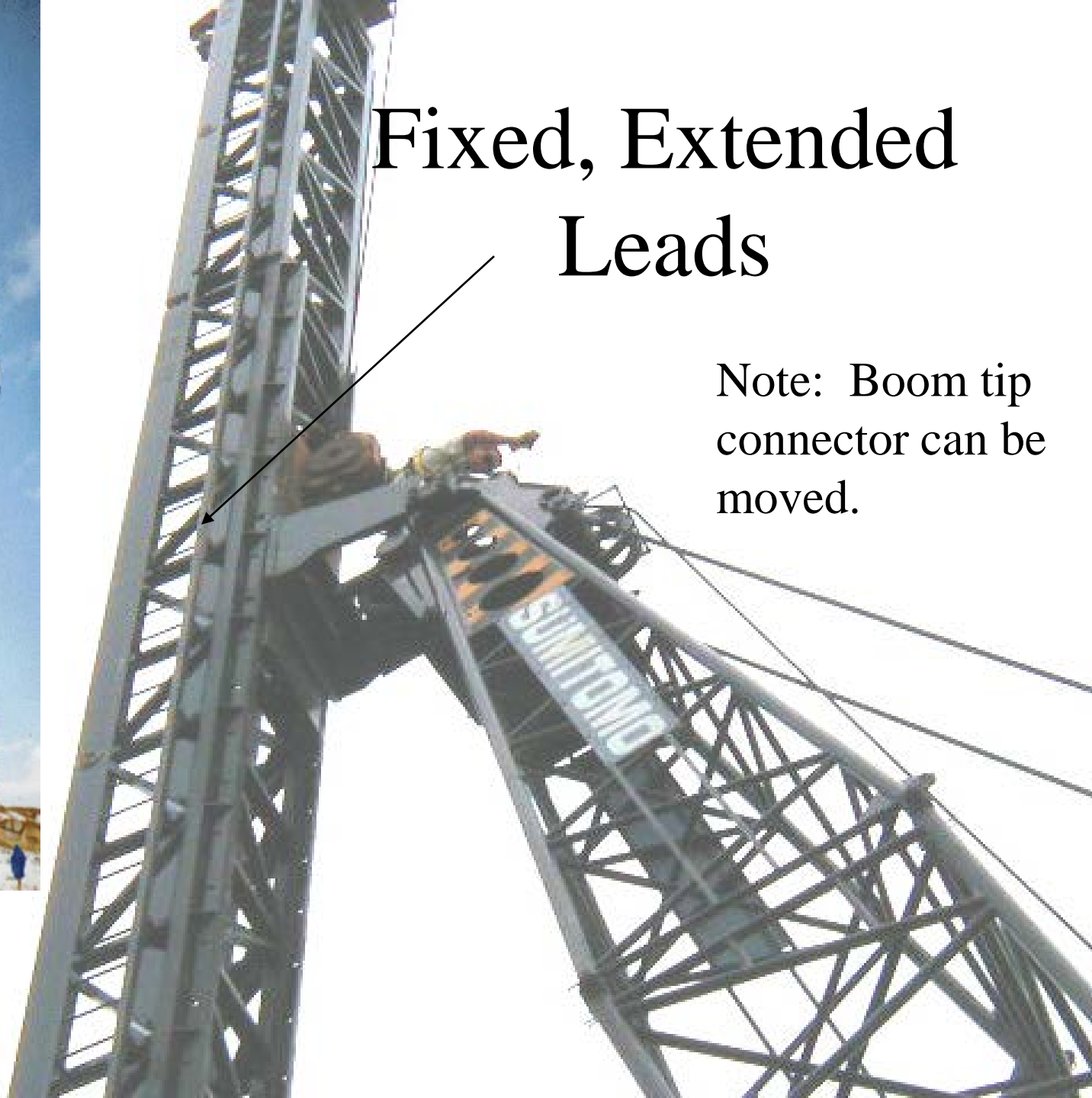

Fixed, Extended Leads

Note: Boom tip connector can be moved.

Boom Tip Connector With Sled

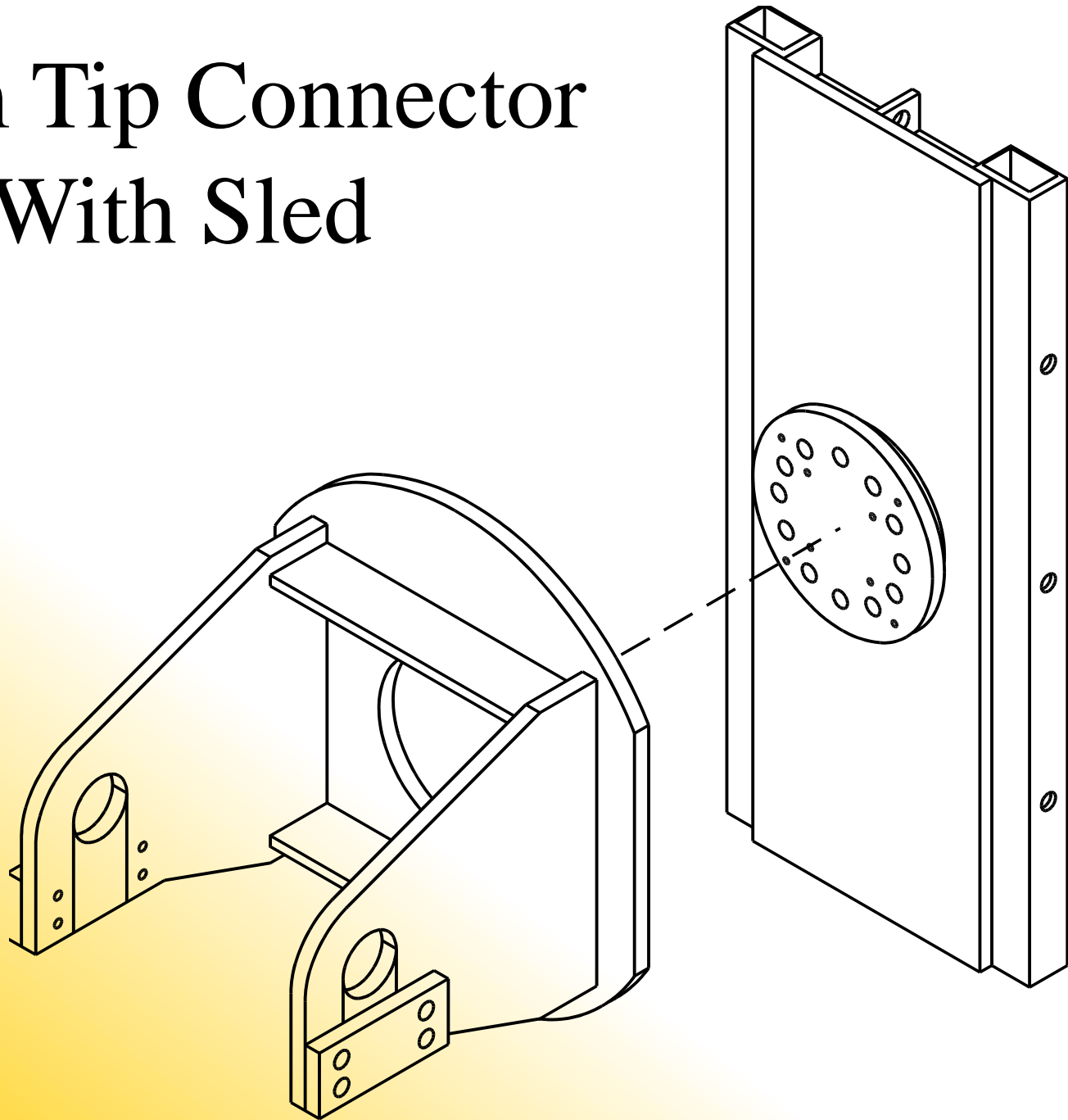



Massive boom tip connector



Boom
point
Connectors



Example of fixed boom point



Two cranes help assist piling crane in picking fixed lead system

Connection to crane boom

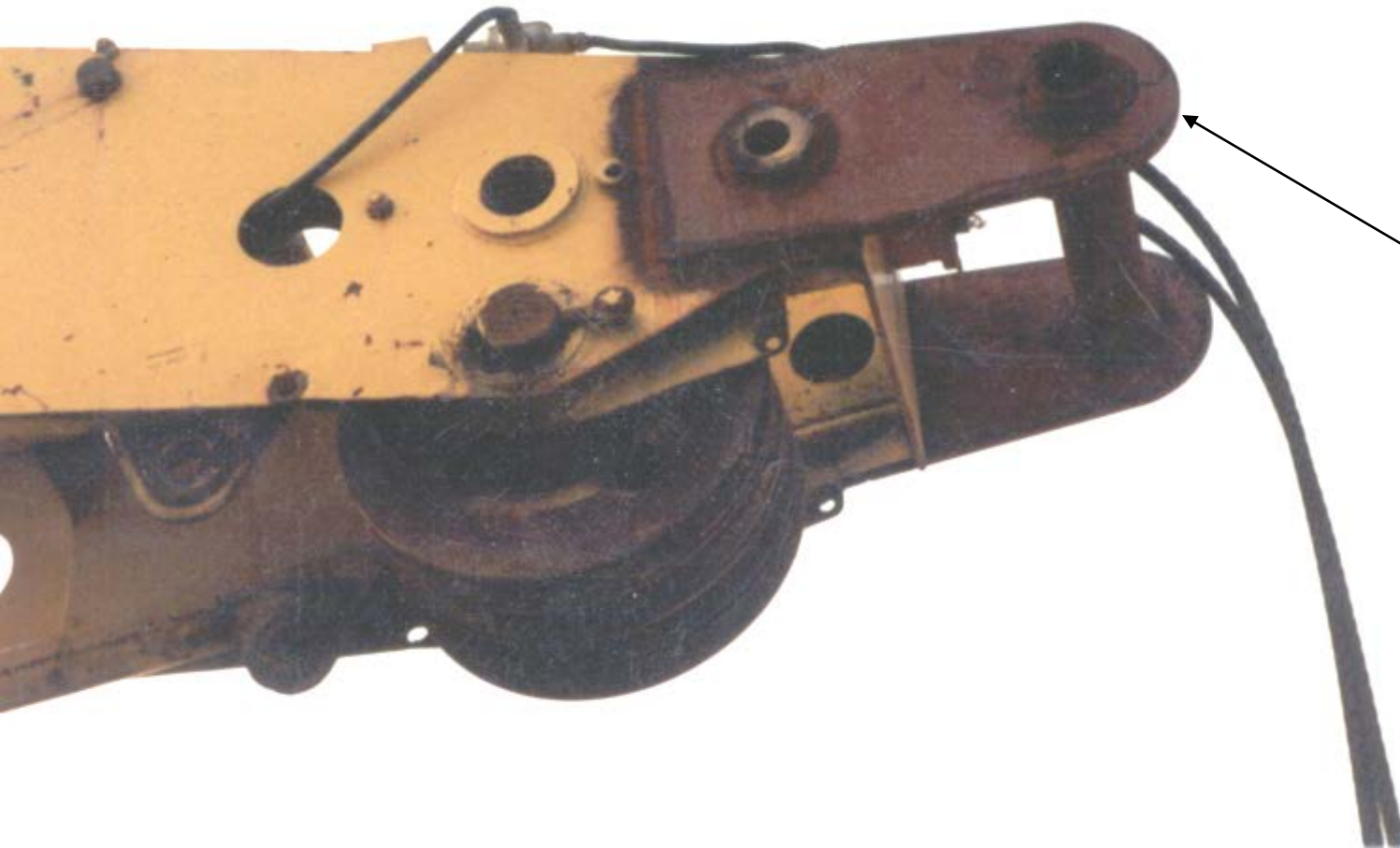

Ears
welded to
crane
boom.

Not a good
practice.



Crane tip, Boom point, & Rooster

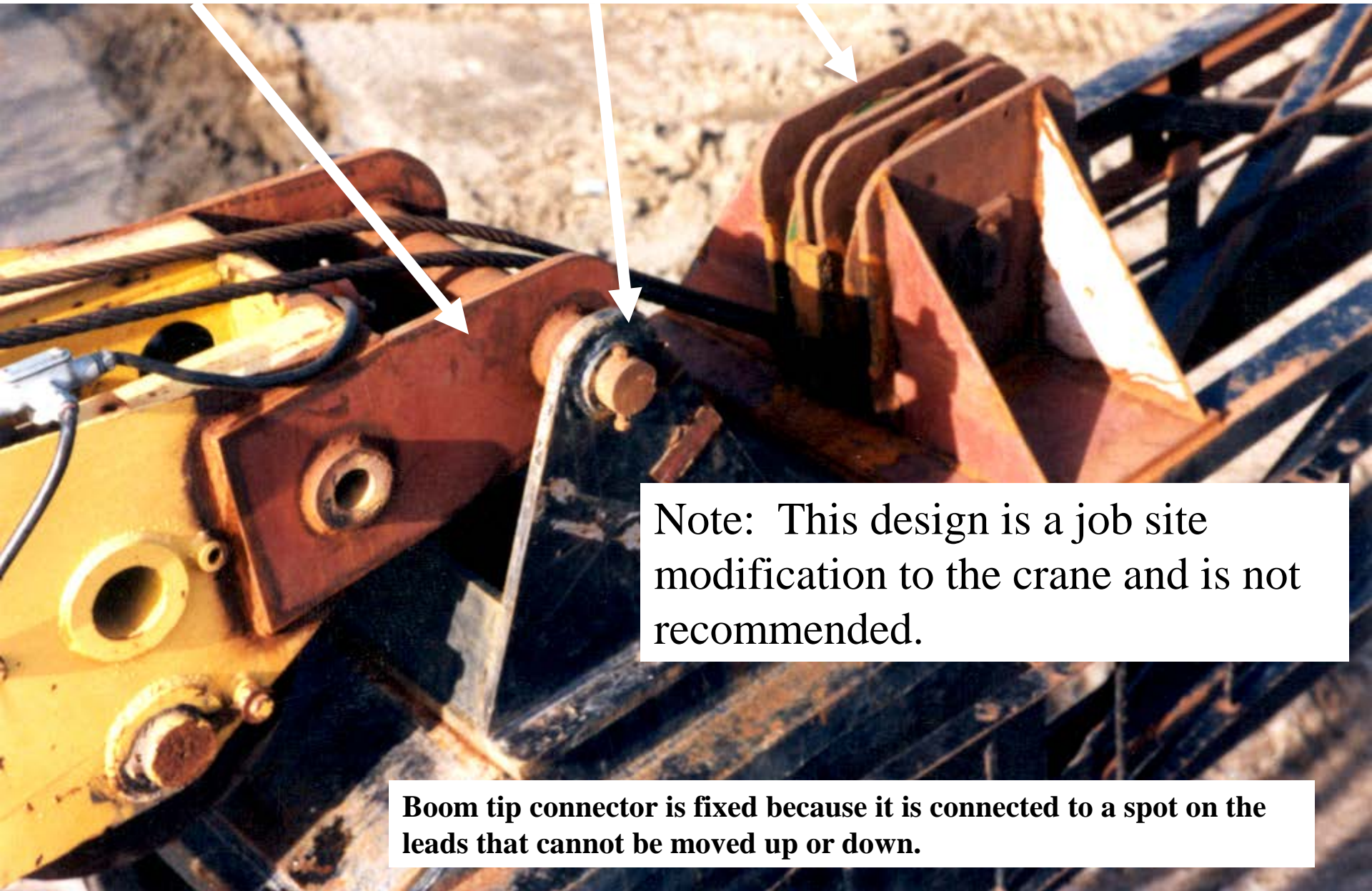

Note: This design is a job site modification to the crane and is not recommended.

Boom tip connector is fixed because it is connected to a spot on the leads that cannot be moved up or down.



One type of Boom tip connector with bolt on mounting plate.

Fixed boom point connector

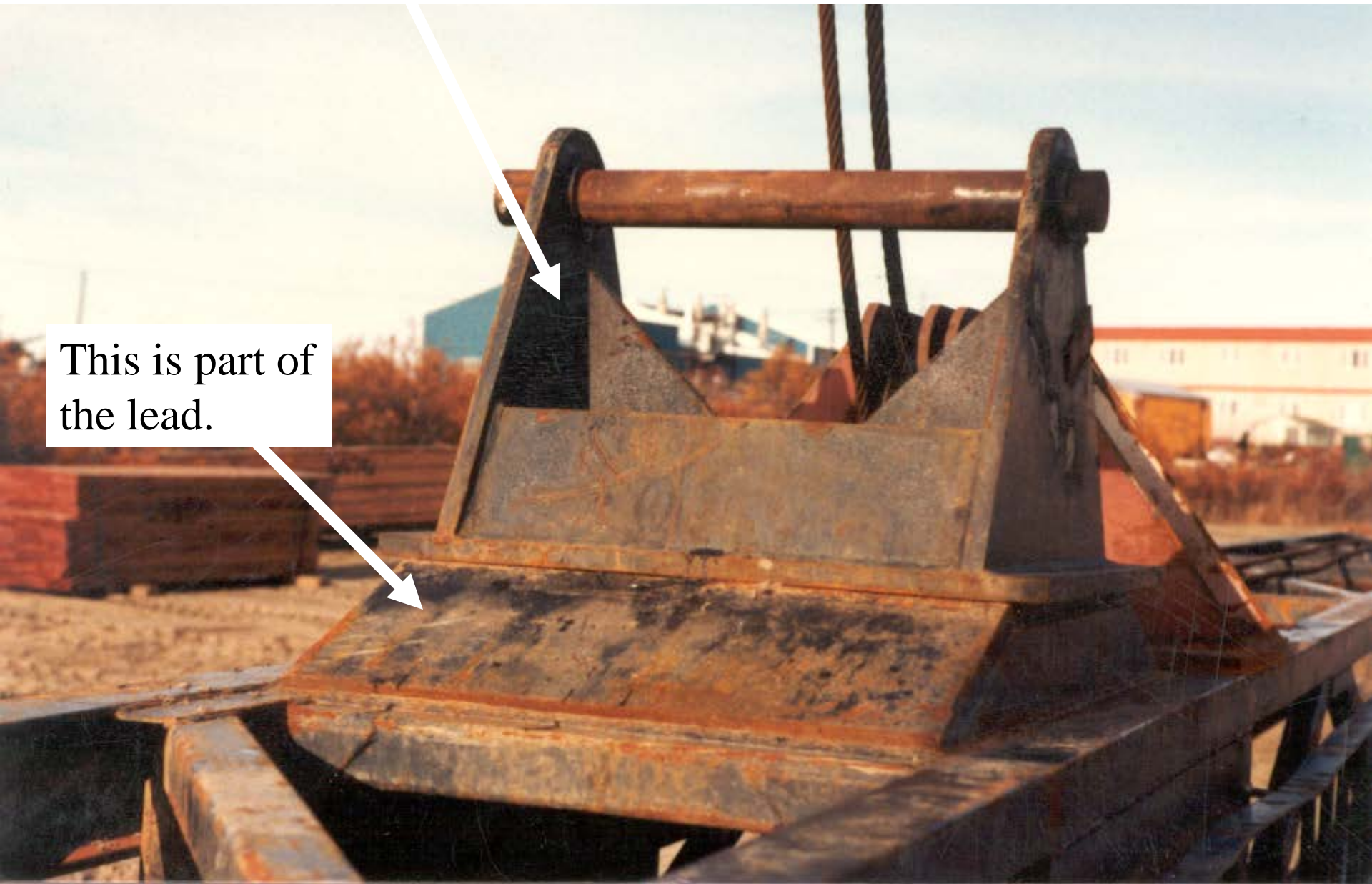

This is part of the lead.

Sliding boom point with easy install pin.



Simple drawing of Boom Point

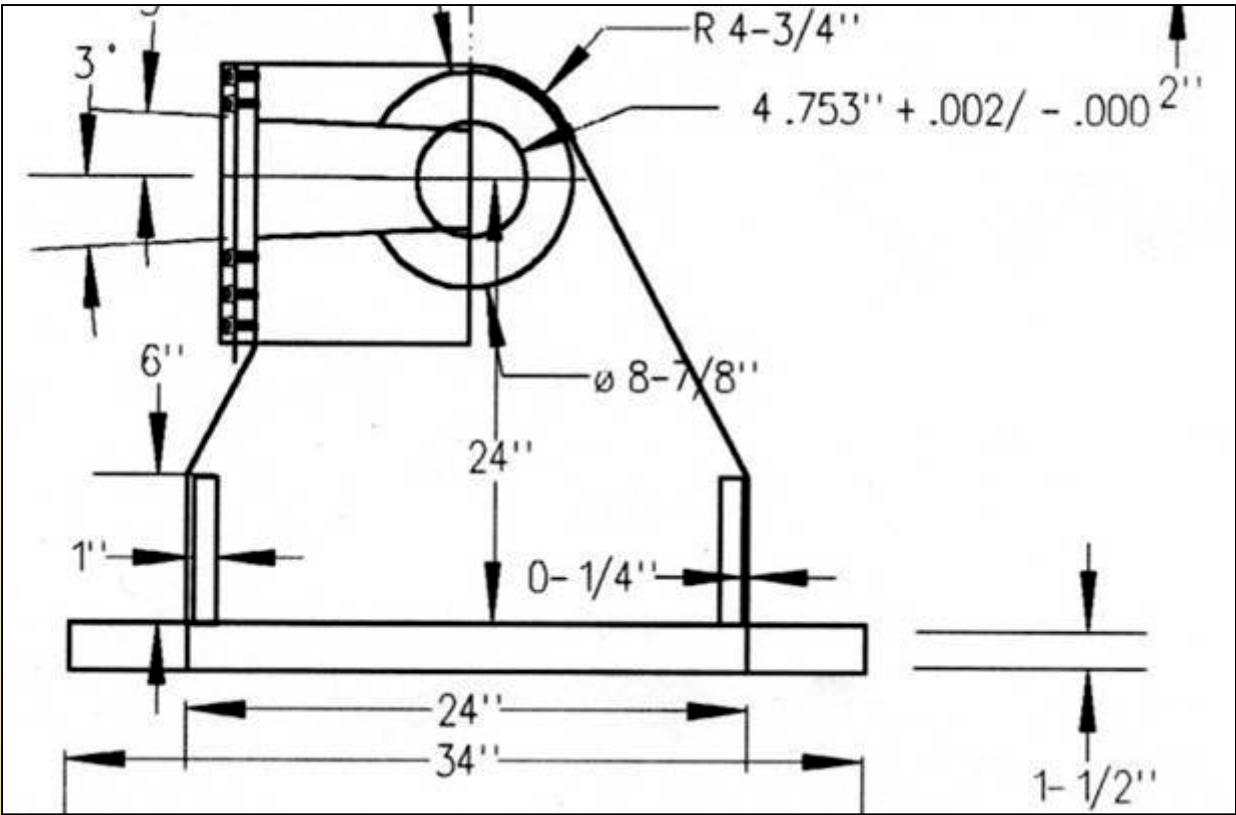



Example of contactor fabricated sliding boom tip connector



Sliding boom tip that is fixed.

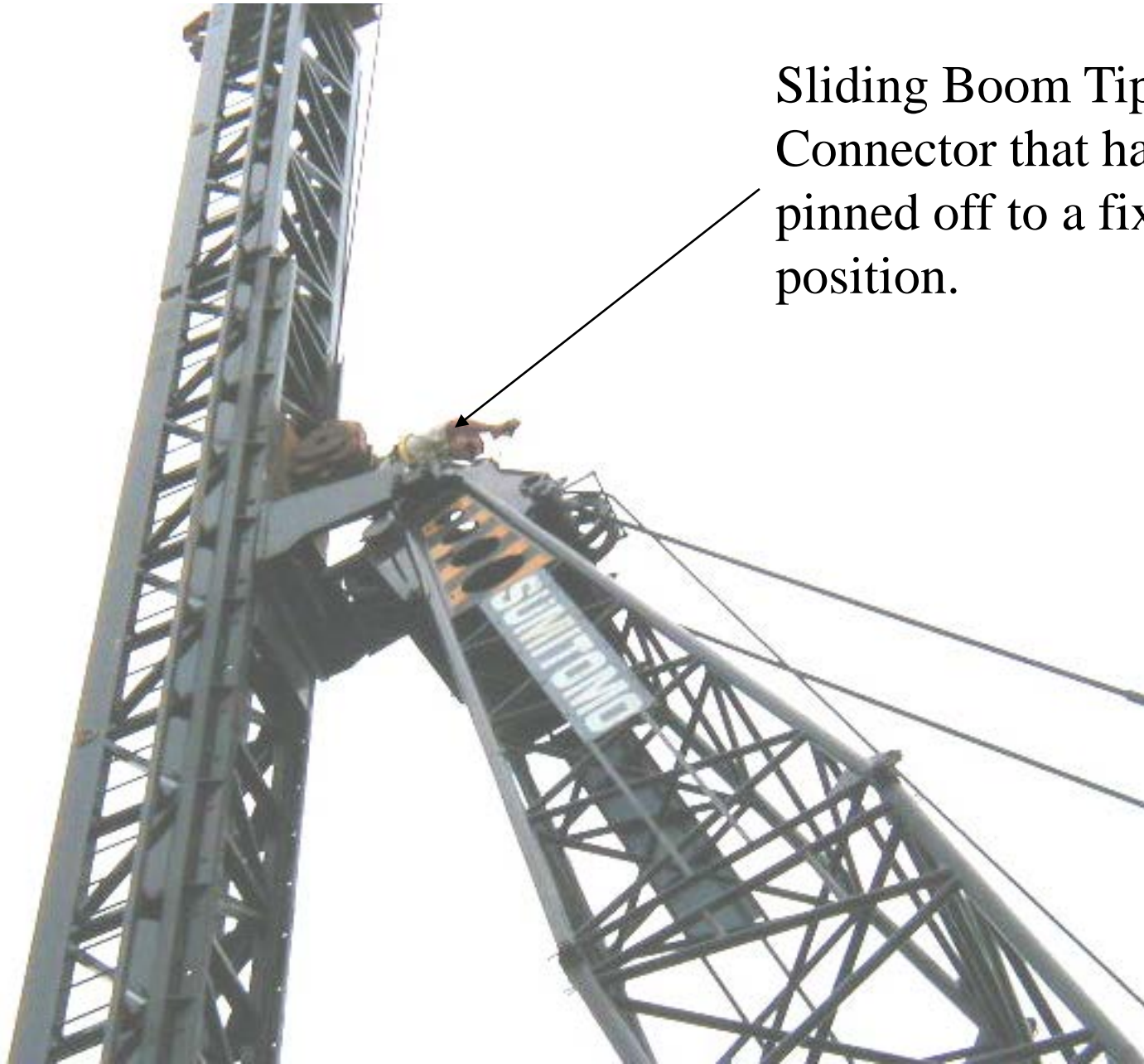

Sliding Boom Tip
Connector that has been
pinned off to a fixed
position.

Headblock

APE HEADBLOCK WITH AUGER SHEAVE

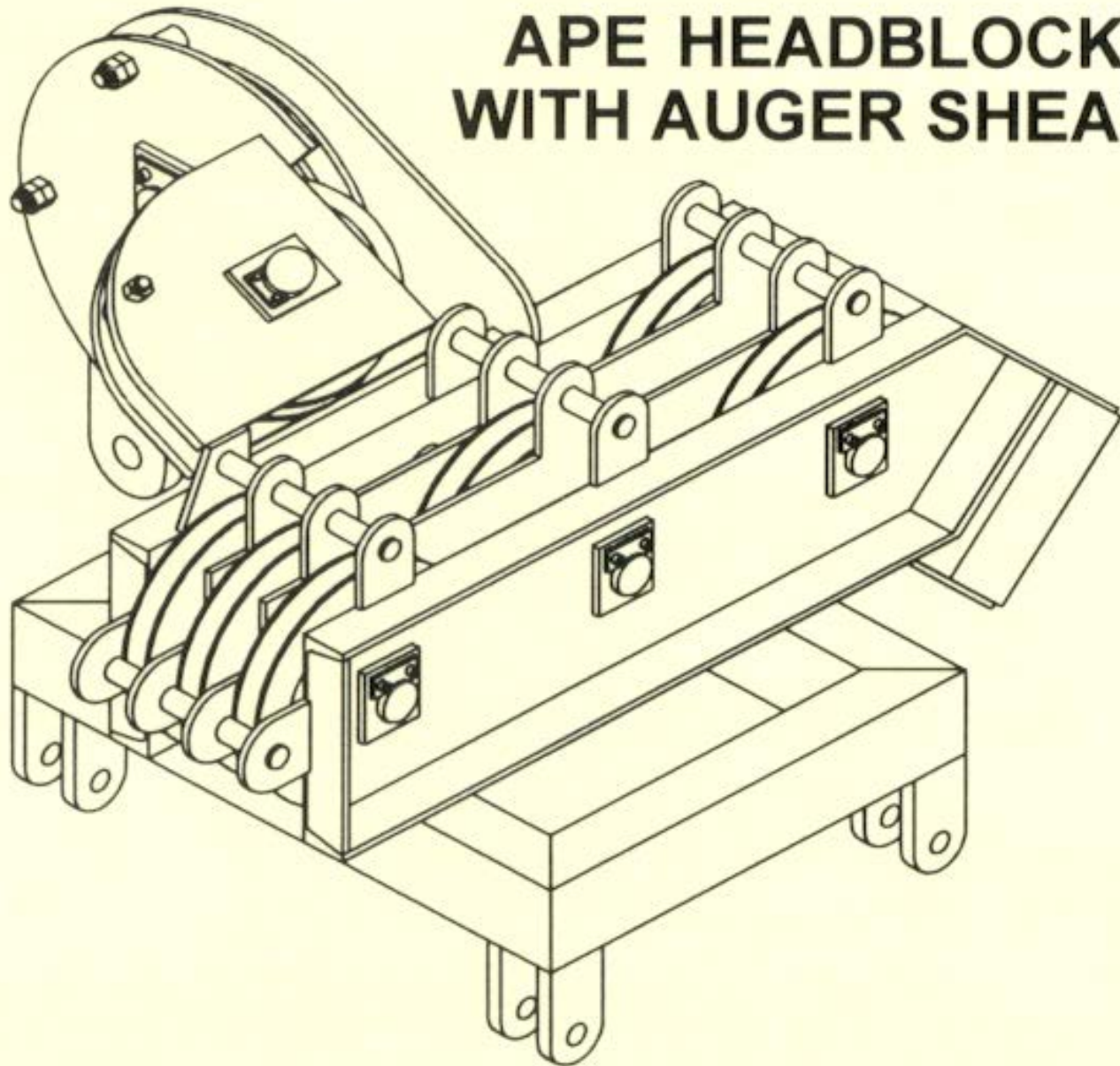

Example Head
Block With Side
Sheaves For
Auger



Boom
Tip &
Roosters

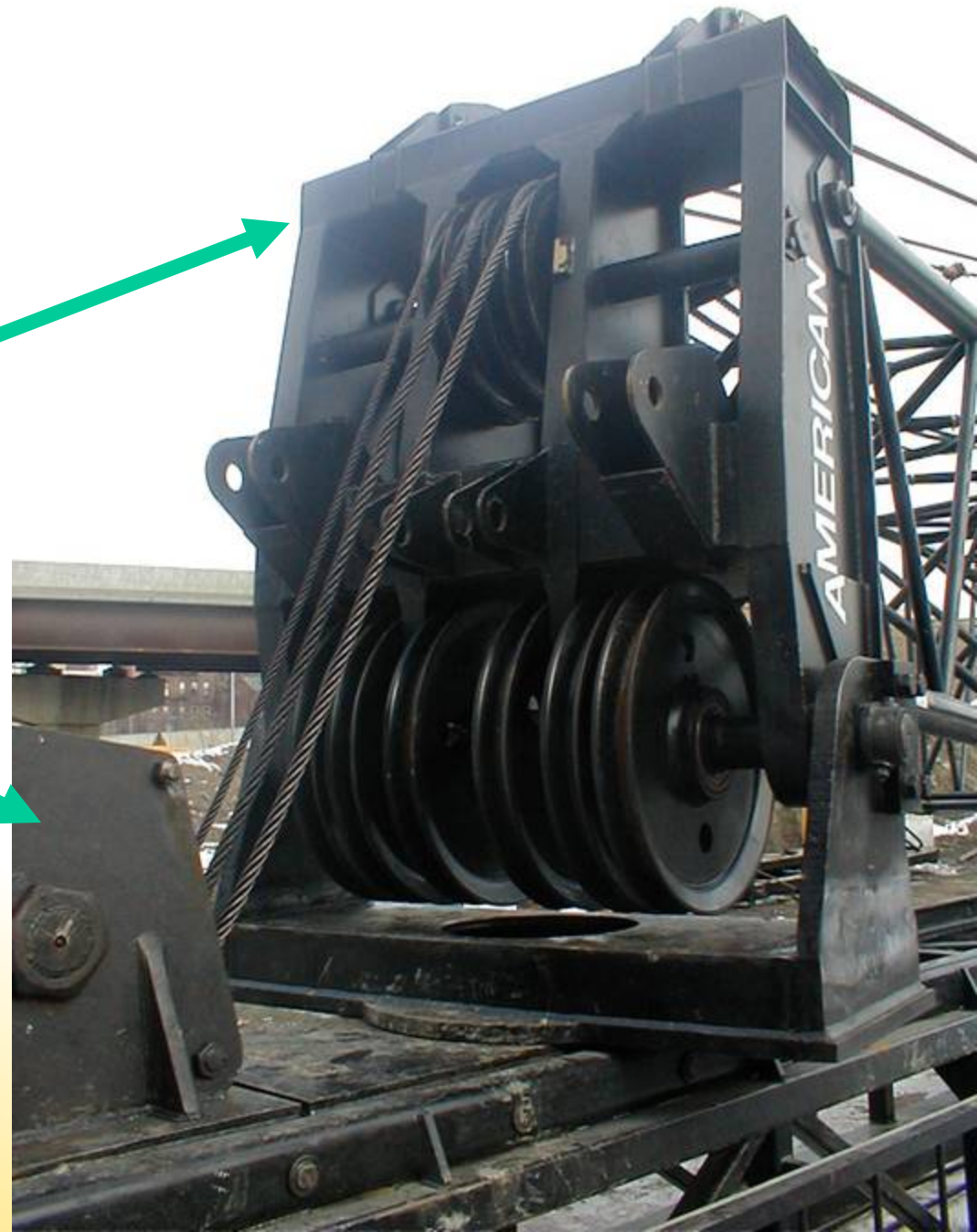

Top View of Headblock



Headblock with side sheave for using an auger.



Spotters



Typical Spotter

17ft. RETRACTED 37ft. EXTENDED

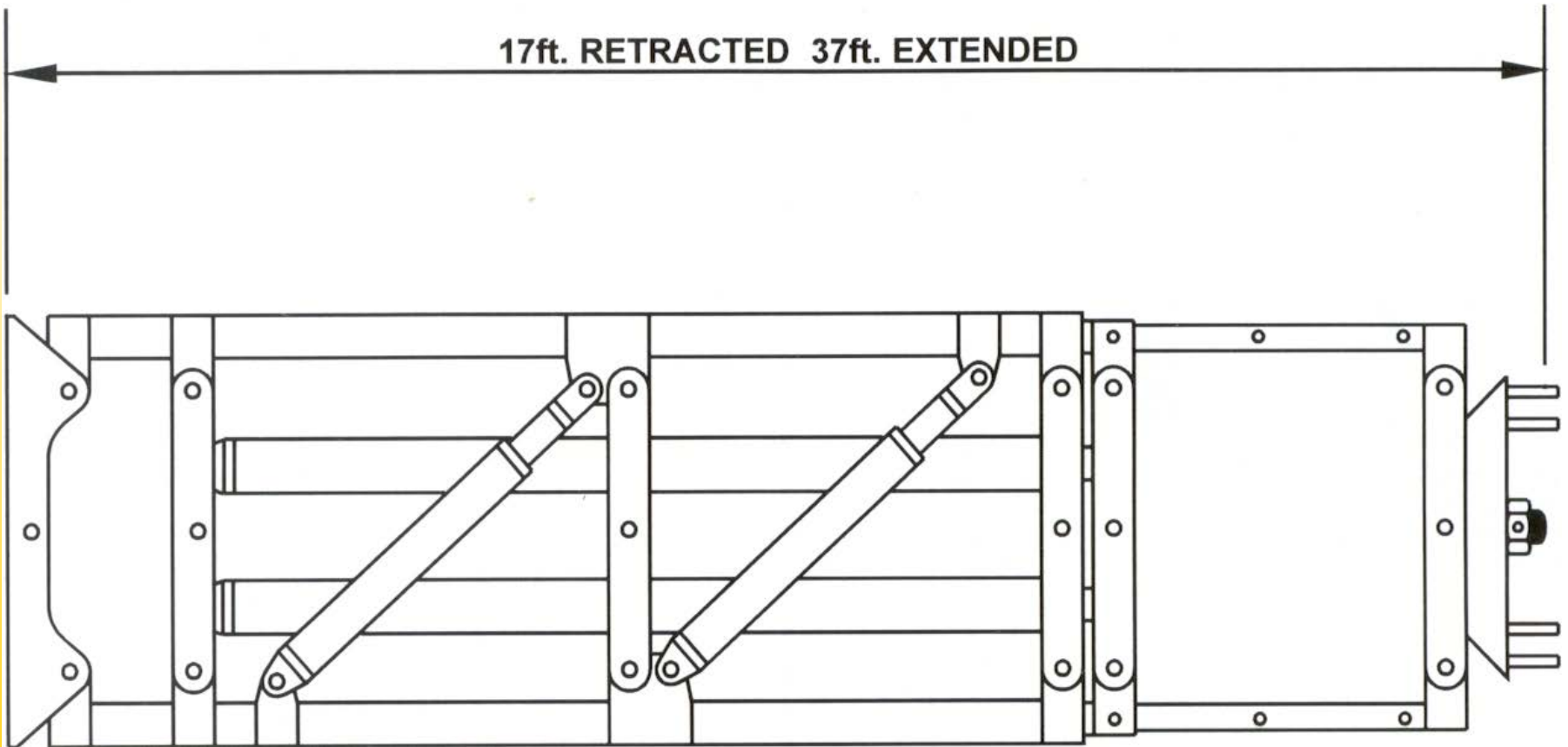

Spotter to Lead Connections



Ladder Safety Device

Fixed Leads with Vibro in Front

Note: Swinging leads can be fit to front of fixed leads to allow for larger hammer to fit smaller leads.





APE Model 400 in leads extracting Concrete Piles

Top View of Vibro in Leads

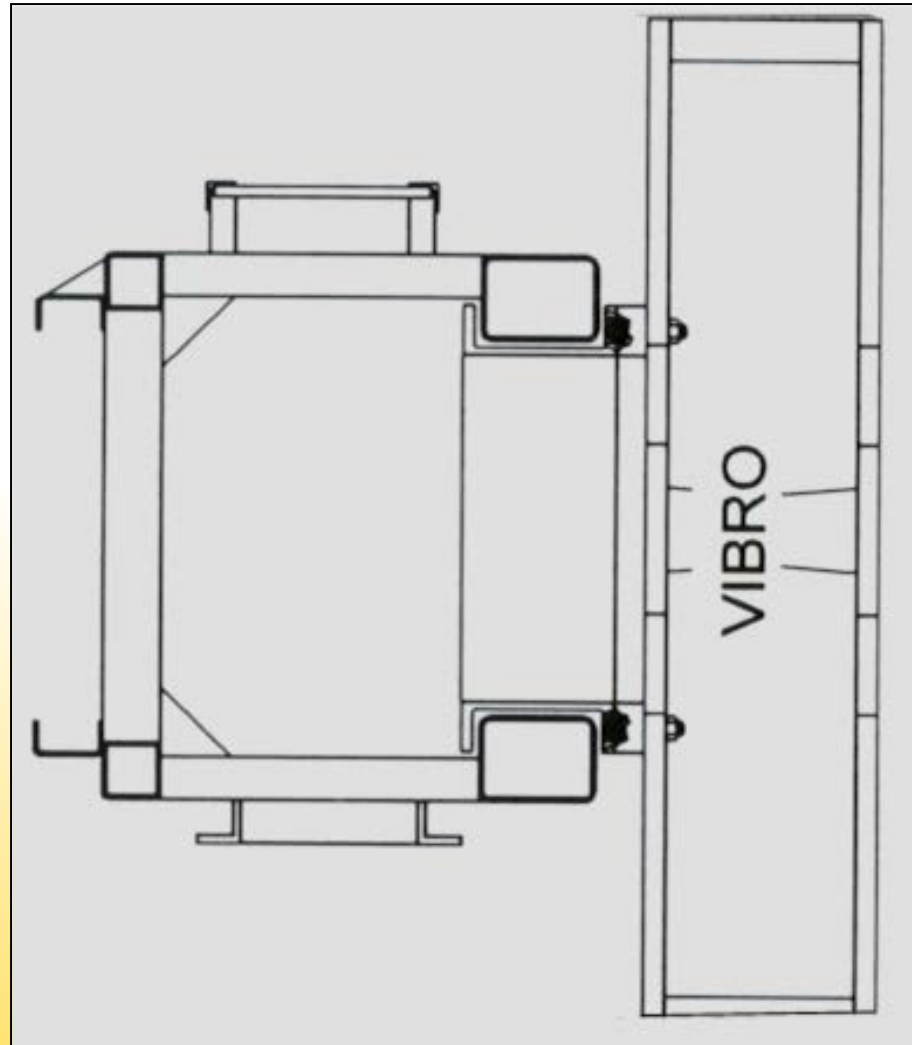

Vibros in Leads



Forklift Mounted Leads



Power Unit Leaders

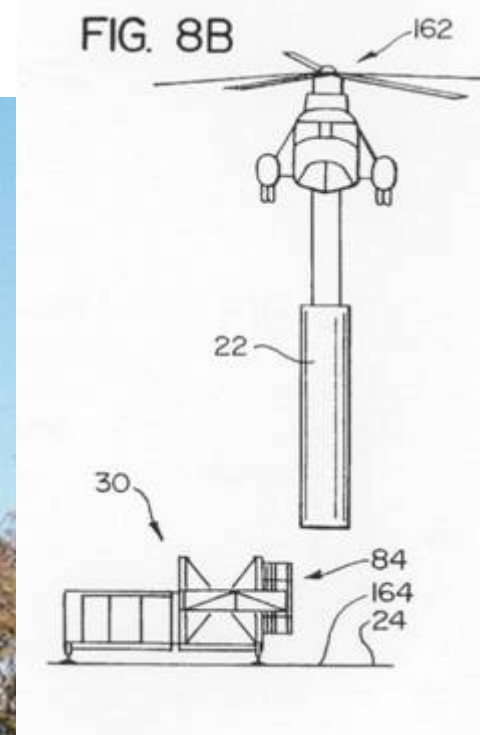

Power Unit Support Leaders



Power Unit Supported Leads





Vibros In Leads

Vibros In Leads



Hydraulic Impact Hammer in Front of Leads



Hammer in
front of leads

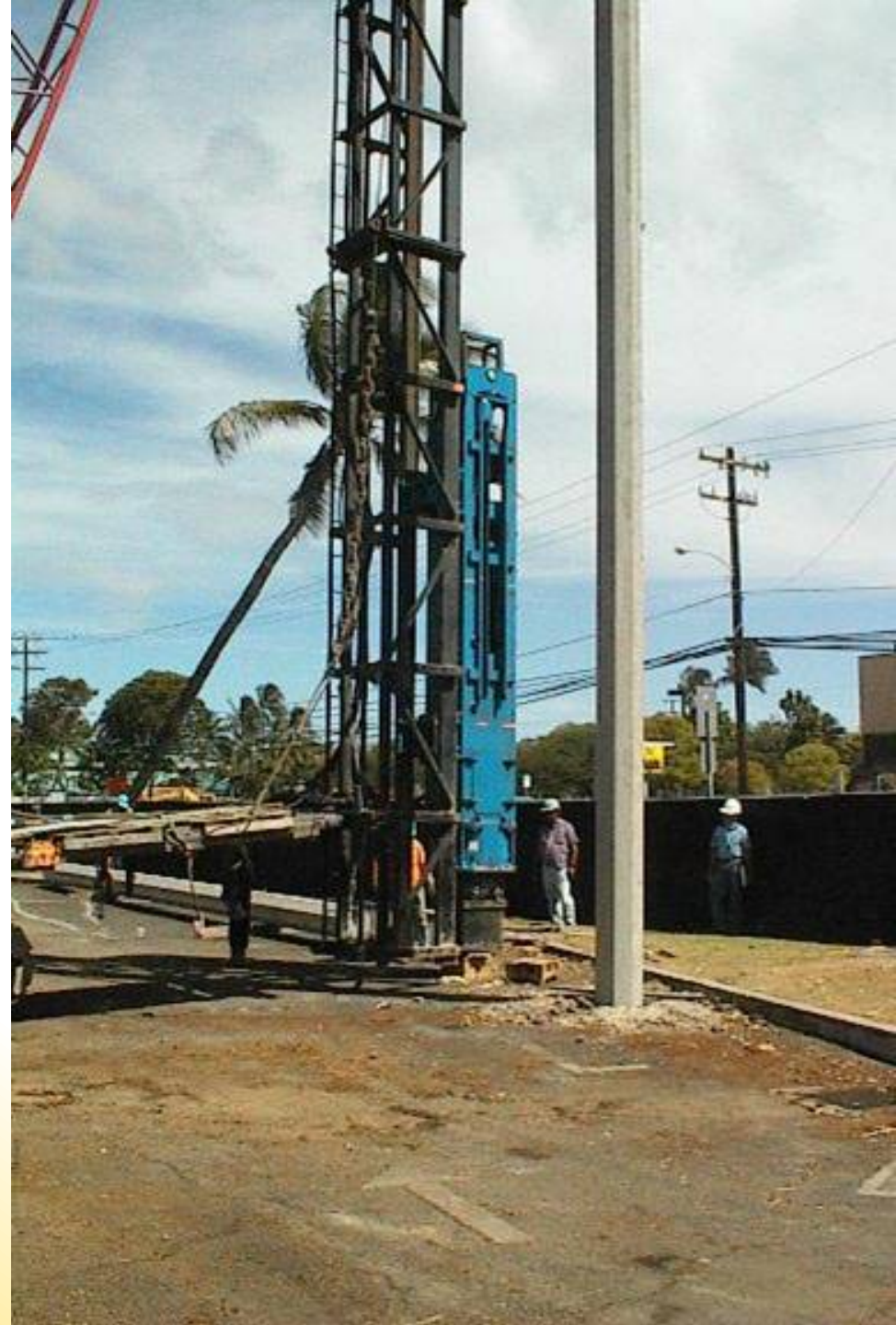

Lead Adapter



Spotters

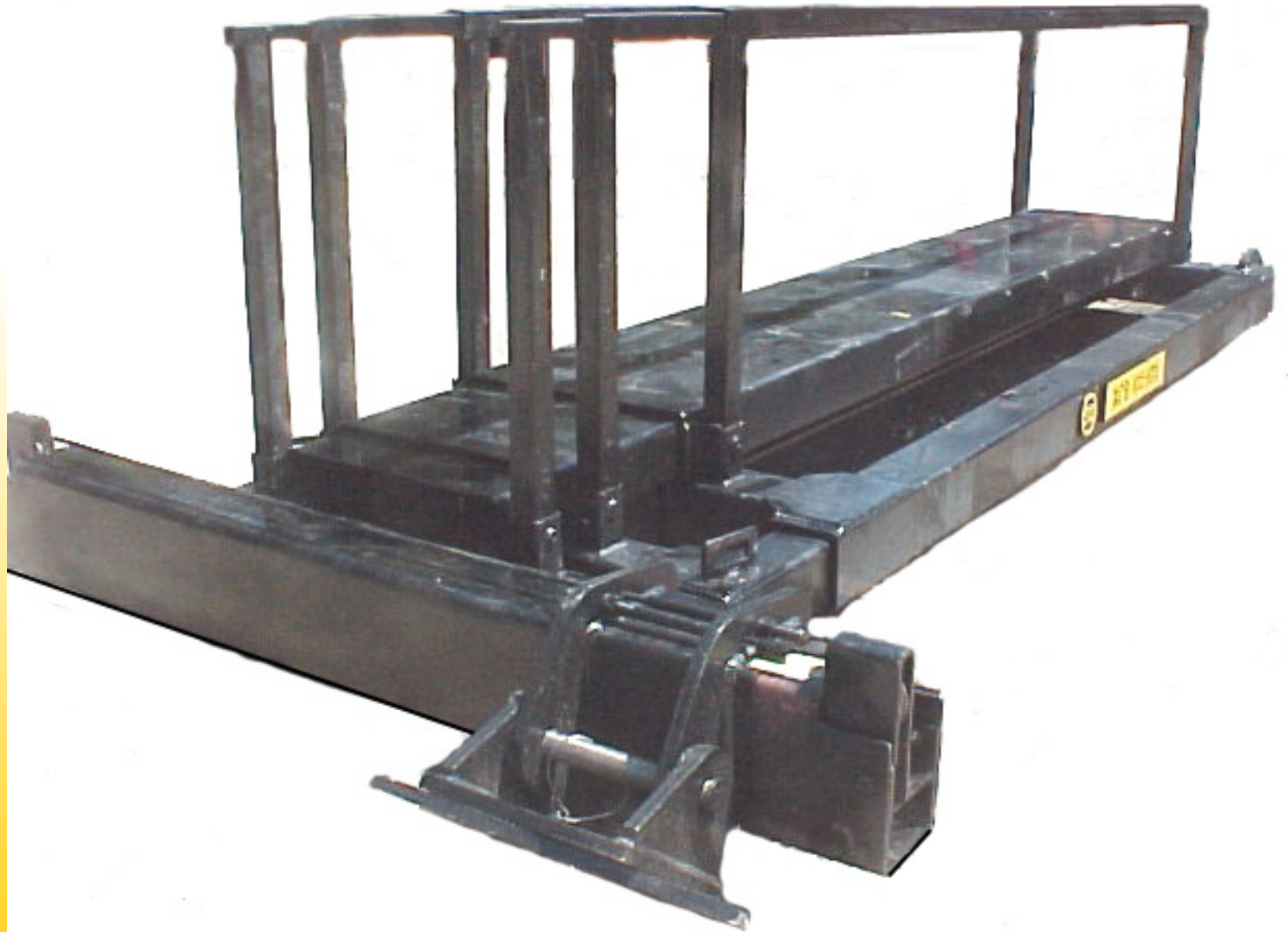

Spotters



Fixed, Extended Travel Leads

Fixed,
Extended,
Vertical Travel

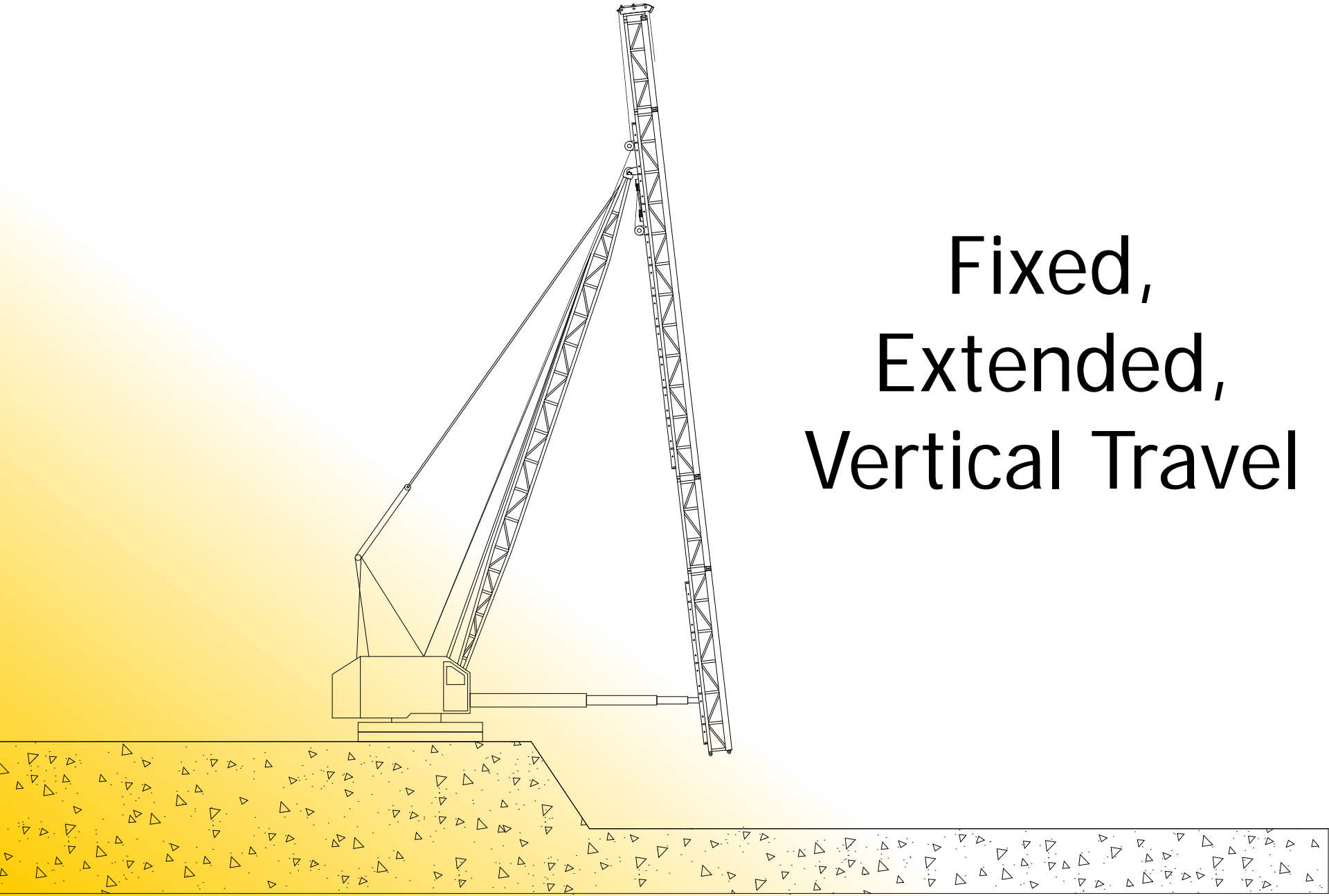

Vertical Travel Leads

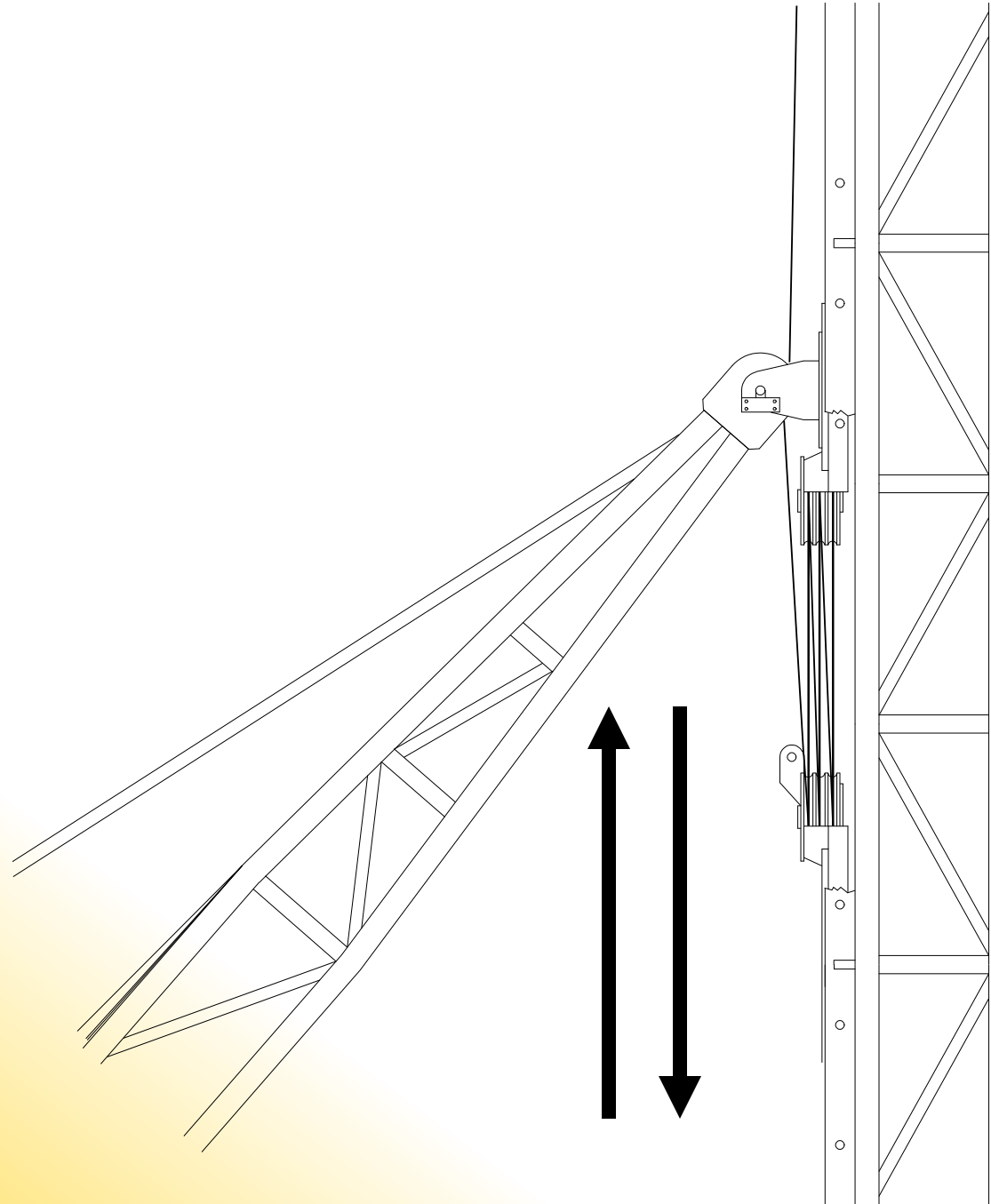

Pogo Stick in a Vertical Travel Leader Type System

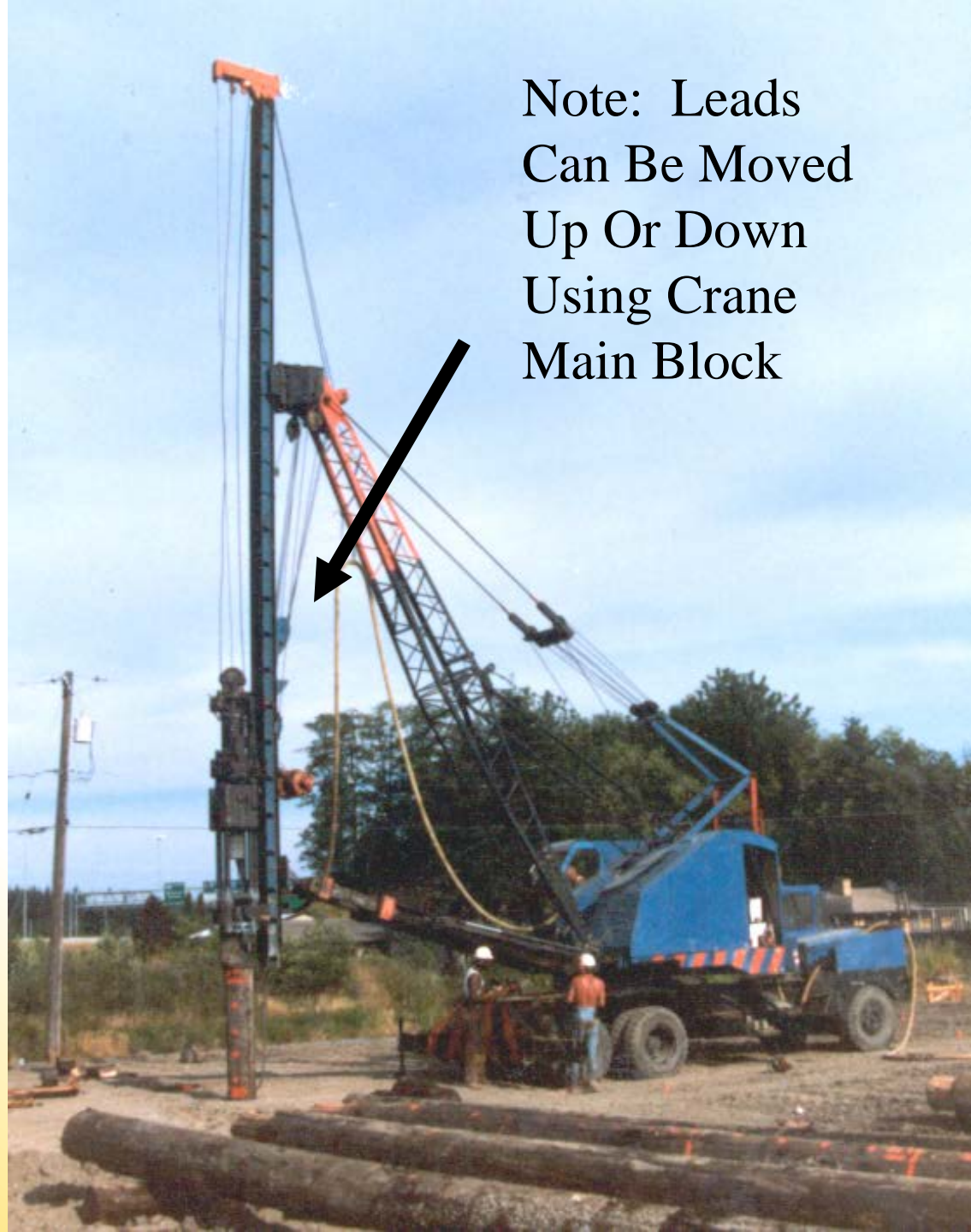

Note: Leads
Can Be Moved
Up Or Down
Using Crane
Main Block

Boom tip
sides up
and down
on back
of leader.

Stops are
welded to
top of
leader to
allow
crane
operator
to boom
up and
pick
leads.

Inside Pogo Stick Lead

Note: Hammer faces
crane operator.

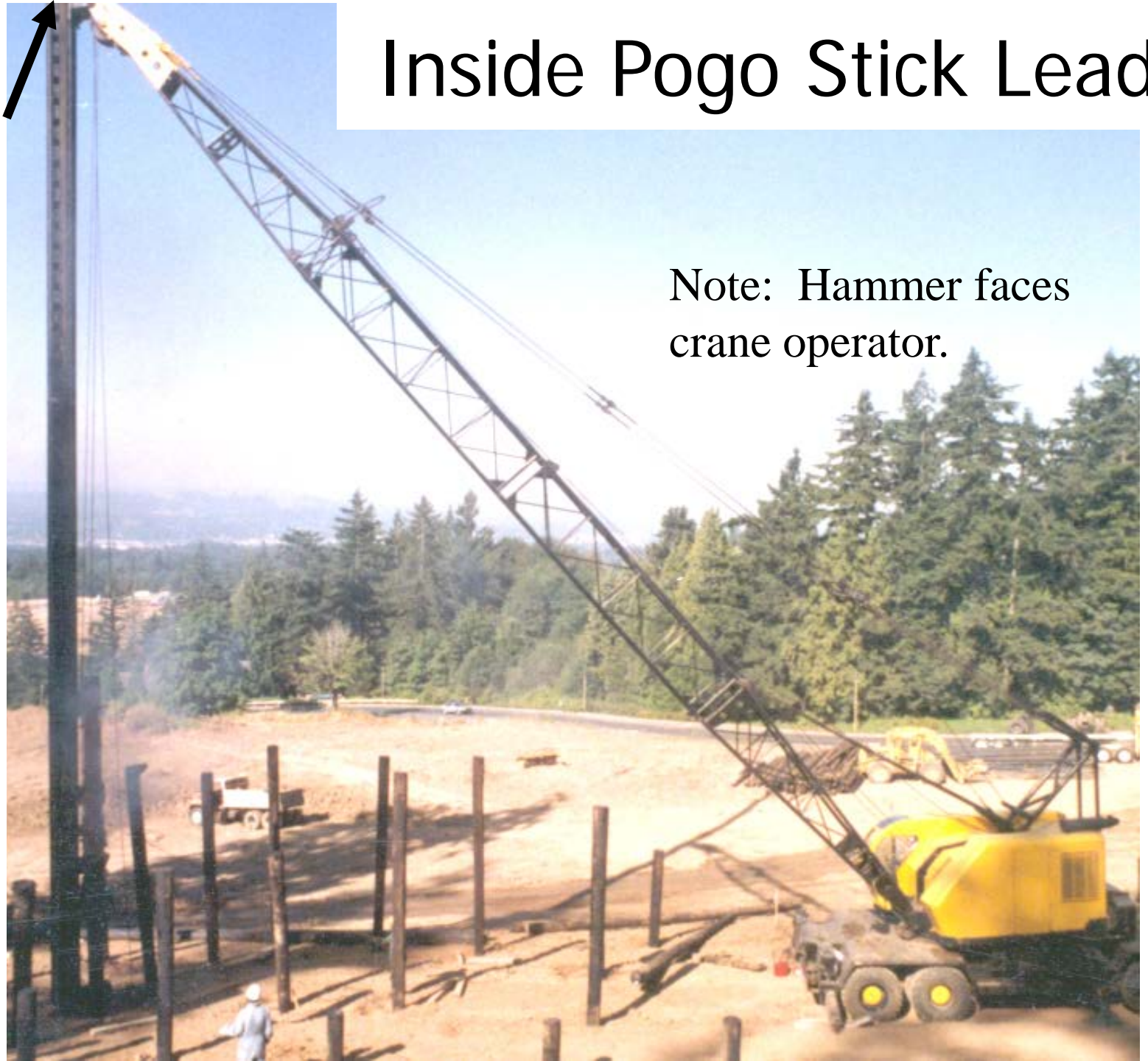



Dangers of extending Leads

Do not read crane charts based on crane boom and lift from this point.

Crane load charts calculate from here.

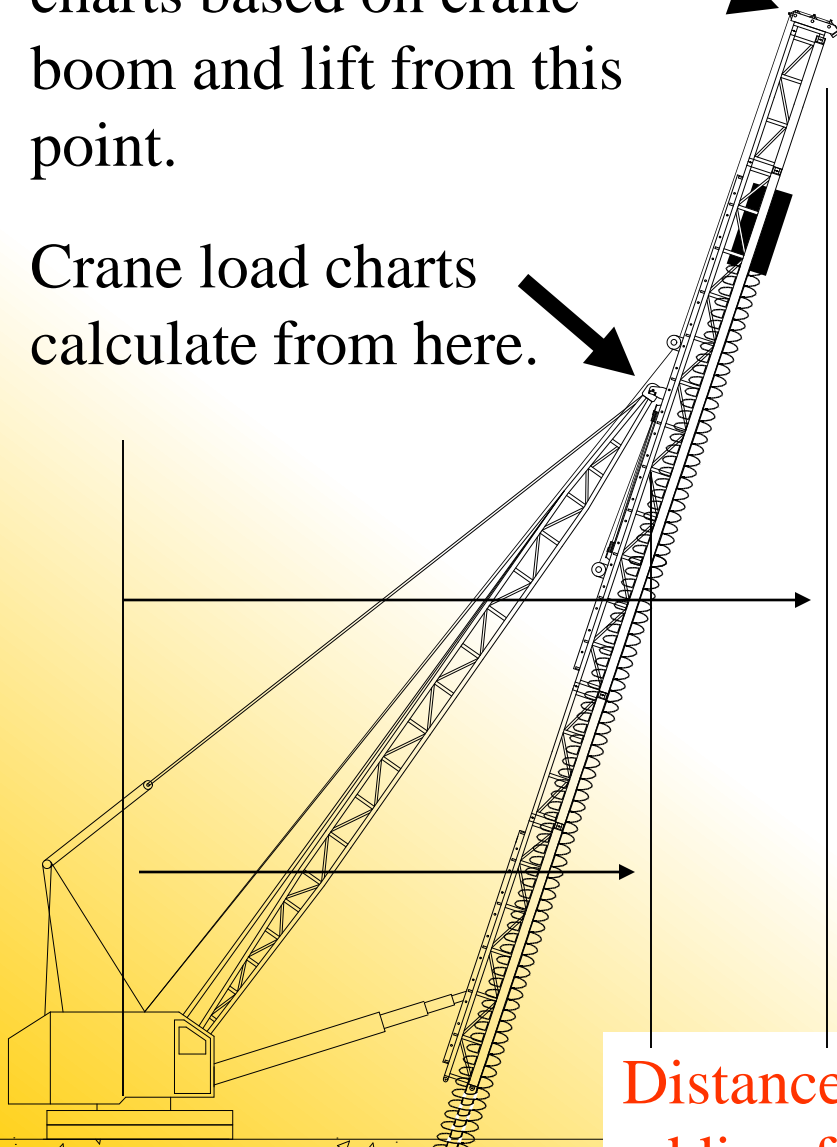

Crane lifting capacity is based on many factors including the length of the boom.

Extending the boom reduces lifting capacity.

When extending the leads above the boom, please have all lifting calculations reviewed by a qualified engineer and the crane manufacturer.

Distance from crane center changes when adding fixed leads and spotting back.



Boot Leads

Boot Leads (John Lucas)



Boot Leads

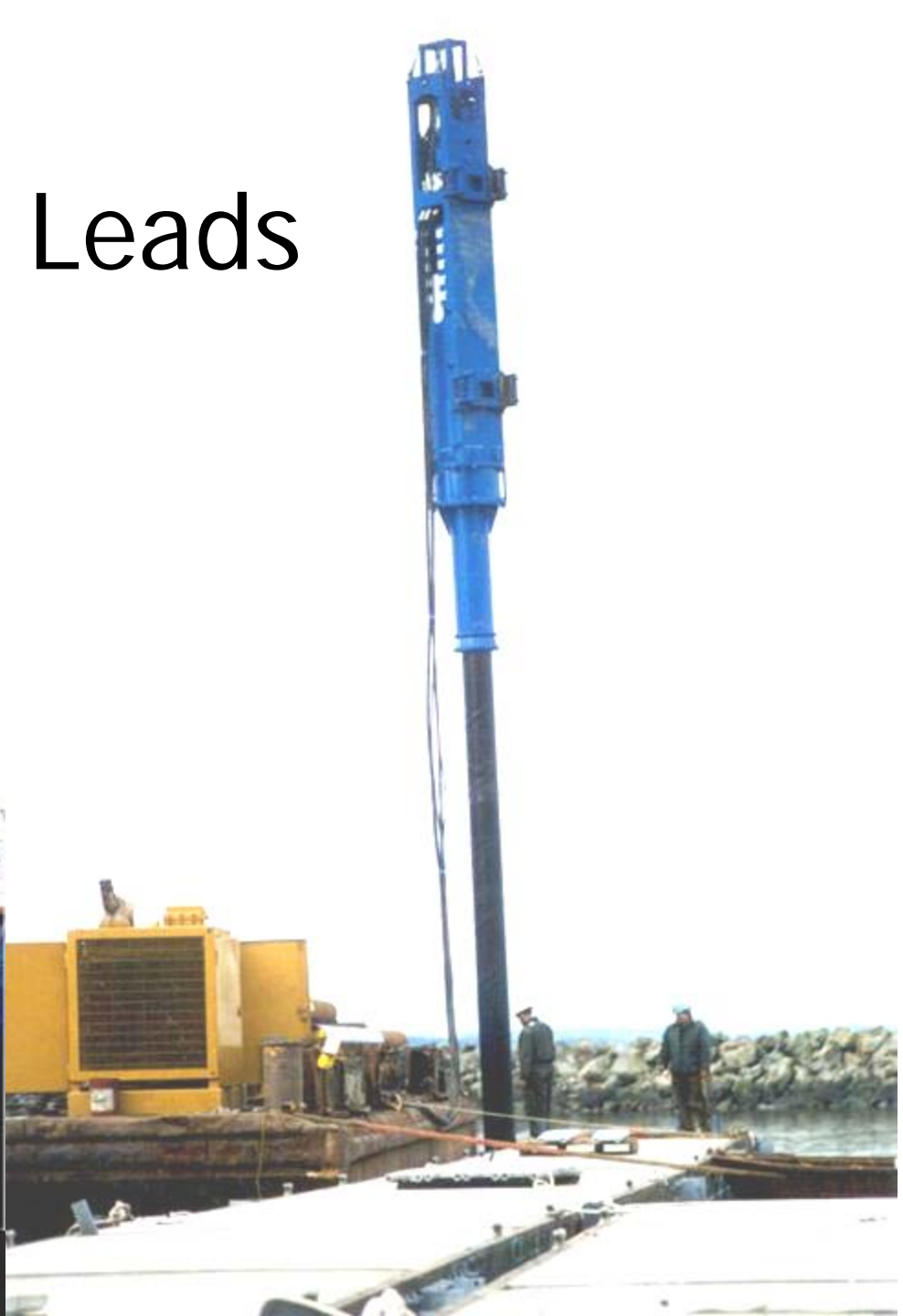

Boot Leads

IHC Hydraulic Impact
and
Woodrow Wilson Bridge





Boot Leads

Boot or pile guide is mounted to bottom of IHC hammer to be used as a leader system.



Boot Leads

APE Model 400 with 400,000 ft pounds and
80,000 lb ram.

Hydraulic and Underwater



Flying Leads On Batter



Flying Leads

Flying Leads On Oil Rig





Off Shore Leads

Flying Leads



Barge Mounted

D100 diesel hammer



New technology
Bottom drive leads
for large pipes.



APE D80 Drives 84" Piles

This photo shows the new APE 37 inch box type leads with a new development pile driving system for super large diameter pipe piles.

This new system is called the "Bottomdrive". It has a much lighter hanging weight and a much lower center of gravity.

The system was first used in California by Lucas Marine. It is now commonly used on many large diameter pile projects.

Another added feature is the ability to drive the pile closer to the ground which is impossible with a conventional offshore type leader system.

If you need to drive large diameter pipe or caissons then this is the only way to go. It is fast, simple, and your crane operator will love it.

Contact Joe Wright at APE Houston for additional information.

This design was jointly manufactured by APE and Bomac Contractors of Houston, Texas.

Bottom Drive

APE D100 driving ten foot diameter caissons in California with FlatIron



Bottom Drive





Excavator Leads

Excavator Leads



Excavator Leads



Excavator Leads



Excavator Leads



Excavator Leads



Excavator Leads

APE Diesel Mounted In Leads





Excavator Leads



Excavator Leads

Model APE 8A driving
pipe piles under a bridge
in California





Excavator Leads

Excavator Mounted Leads





Excavator Leads

Excavator Leads



Rig Leads



Special Leads

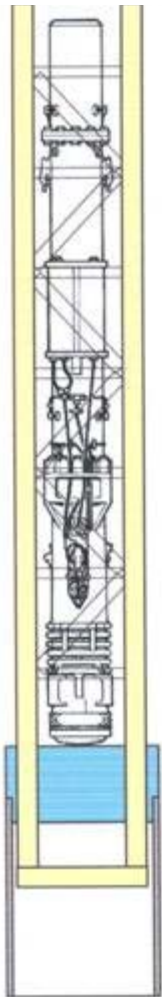

This special lead system allows to drive steel pipe piles close to each other.

The leader is supported by the crane and allows the diesel hammer to slide up and down. The special machined drive cap / helmet is also guided by the leader which guarantees the correct line and the optimum transfer of the impact energy to the pile.

Drive cap / helmet machined to fit inside the casing pipe

Bottom cross bar

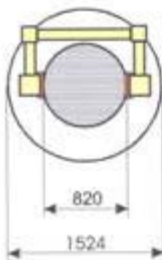

Top view of hammer, lead and drive cap

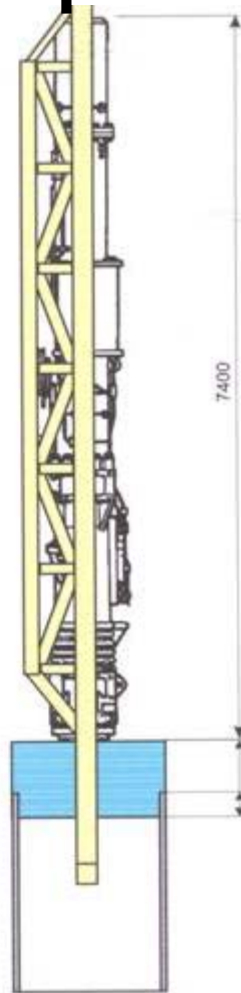

7400

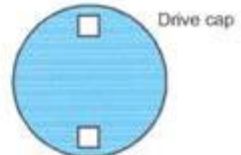

Drive cap

slides up and down in leads. Hammer cannot fall out the bottom of the leads because drive cap cannot fall off the two guide rails.



Hammer

Front view

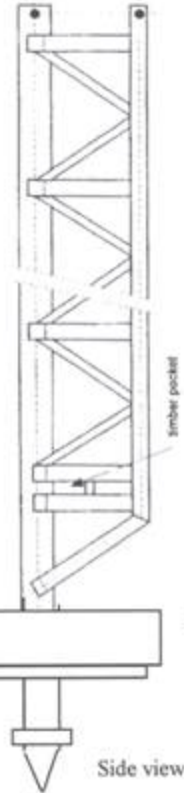

Timber pocket

Drive cap

machined to fit inside of pipe pile.

Side view

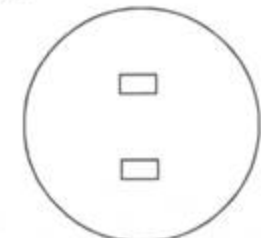

Top view of drive cap

APE D100 and D62 fit in same leads or we can provide two sets of leads so the crew will not need to pull the D100 out and stick the D62 in.

For driving pipe piles right next to each other.

Special Folding Leads

***APE FEC
Folding leads***

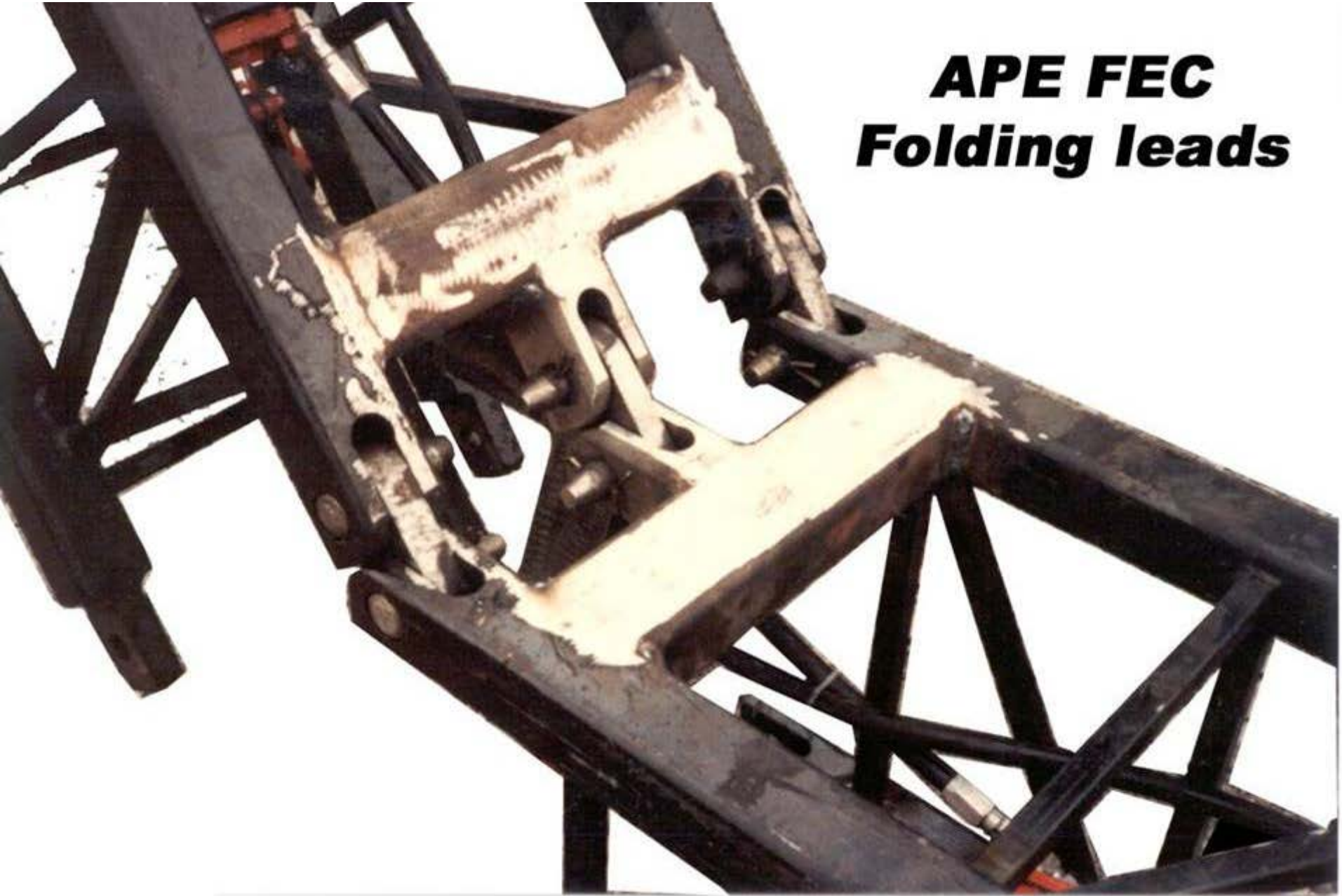



APE rack and pinion drive leader system

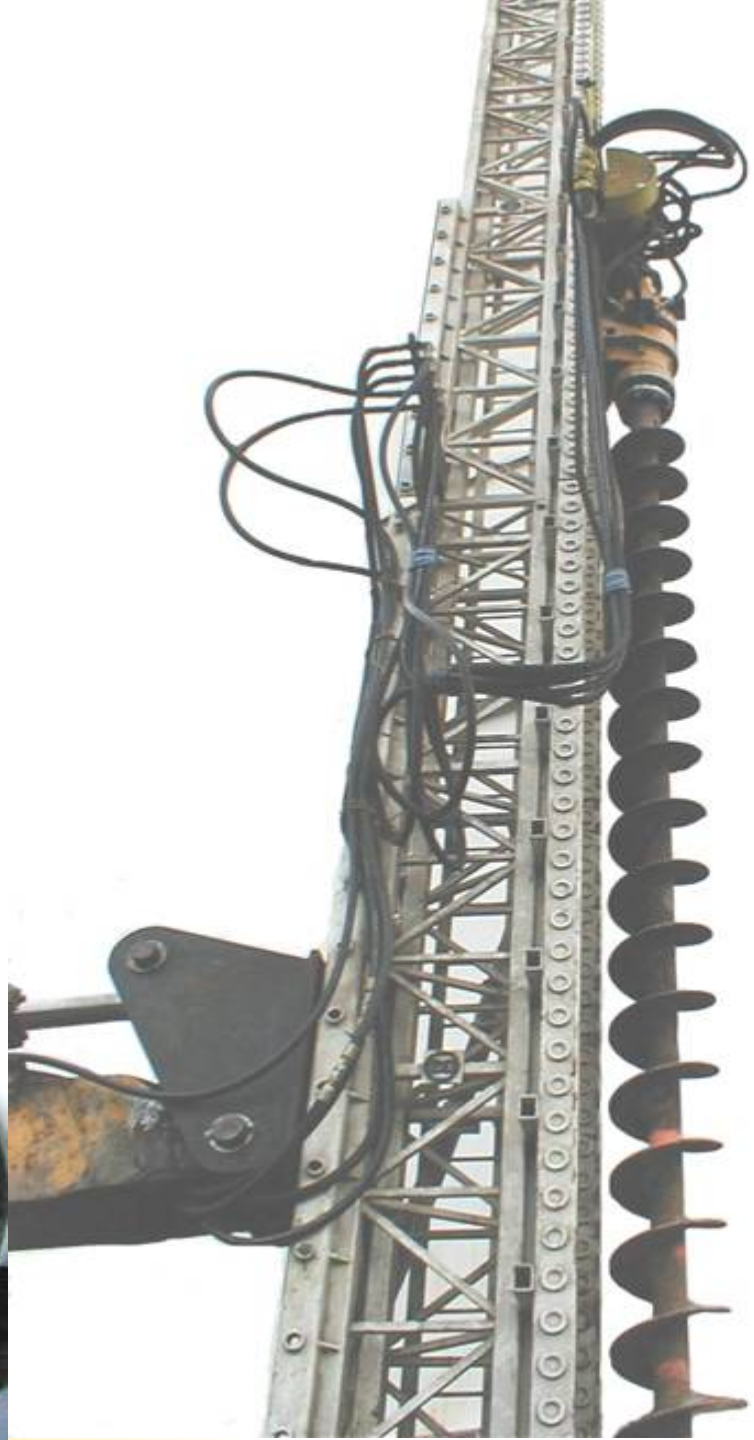
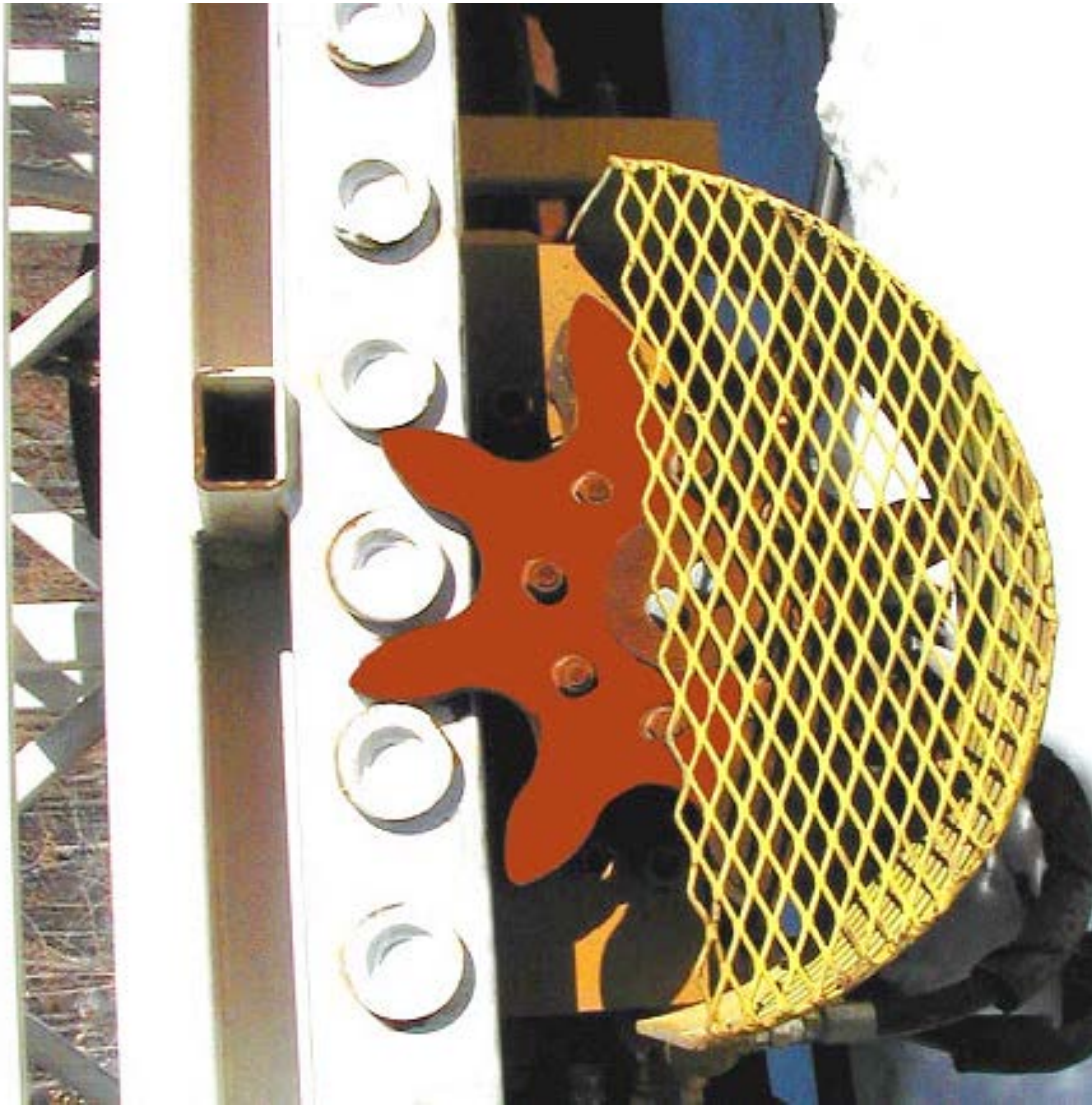

Excavator Leads



Excavator Leads



Excavator Leads



Vibros in Leads

This photo shows an MKT V-20 mounted in leads for the West Seattle Bridge Project in the early 1980's.

It was the first time a vibro was mounted in leads on the West Coast of the USA.



V-20 MKT Mounted In Leads

Vibros in Leads

APE Model 400 mounted in front of leads to drive pipe piles.

San Francisco, California

Kiewit Construction



Vibros on Forklift Leads



Leads for



Wick Drains

Vibros in Leads



Leads with Pull down

